

DRINKS | Drink Cabinets

DRINK COOLER ► UPRIGHT COOLERS

RCF 145

CUSTOMIZATION AVAILABLE
PERSONALIZZAZIONE DISPONIBILE

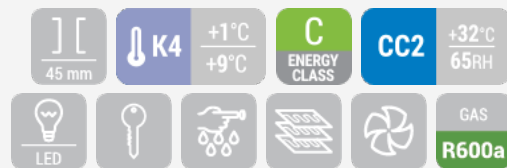

DETAILS

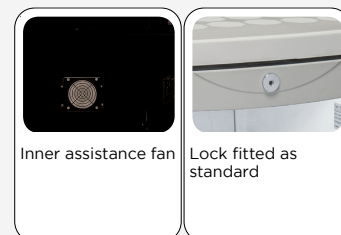

GENERAL FEATURES

- 115 Lt. Upright drink cooler
- External in white coated plate, white thermoformed internally
- Roll-bond evaporator system with fan assisted cooling
- Manual Defrost
- Foaming Agent Cyclopentane (45mm per side)
- Removable Gasket
- Independent switch for internal light
- Double layer safety tempered glass (Curved)
- Digital thermometer
- Reversible door
- Lock fitted as standard
- Adjustable shelves (White Color): 3 Pcs
- N.4 Adjustable feet
- Energy efficiency class: C

TECHNICAL SPECIFICATIONS

Capacity	115 L
Temperature	K4 (+1°C-+9°C)
Consumption	2.76 kWh/24h
Rated Power	90 W
Noise level	47 dB(A)
Net Weight	37 Kg
Gross Weight	40 Kg
External Dimensions (WxDxH mm)	505x590x855
Internal Dimensions (WxDxH mm)	410x395x700
Packaging dimensions (WxDxH mm)	580x620x880
Loading quantities 20'/40'/40"HQ	72/158/220

PRODUCT DIMENSIONS

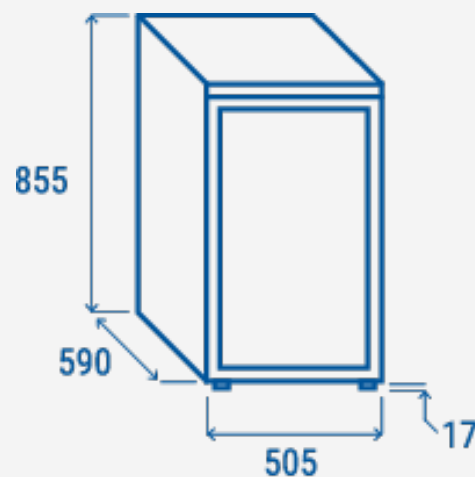

CERTIFICATION

CE RoHS

