

MEAT

275-276

551-552

1151-1152

I
UK
D
E
F



INSTALLAZIONE E USO
INSTALLATION AND USE
ZUSAMMENBAU
UND BETRIEB
INSTALCIÓN Y USO
INSTALLATION ET
MODE D'EMPLOI



MANUTENZIONE
MAINTENANCE
INSTANDHALTUNG
MANTENIMIENTO
ENTRETIEN



COLD
ENGINEERING
TECFRIGO

Manuale Originale
in ITALIANO



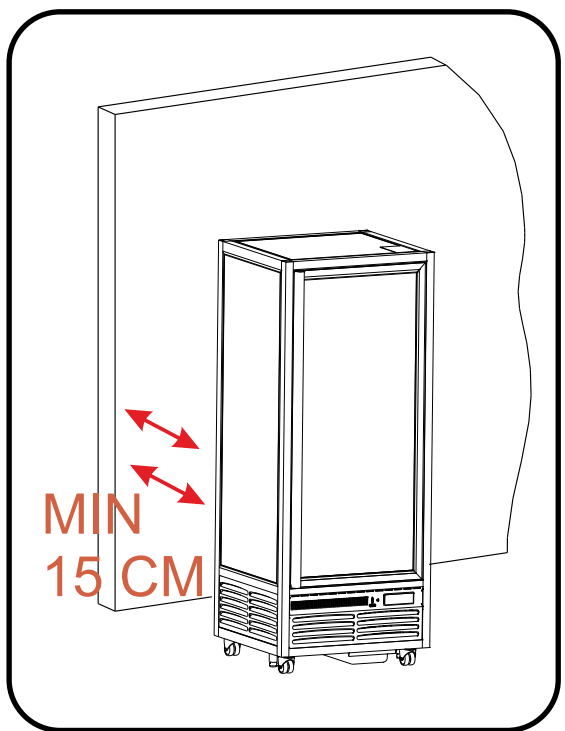
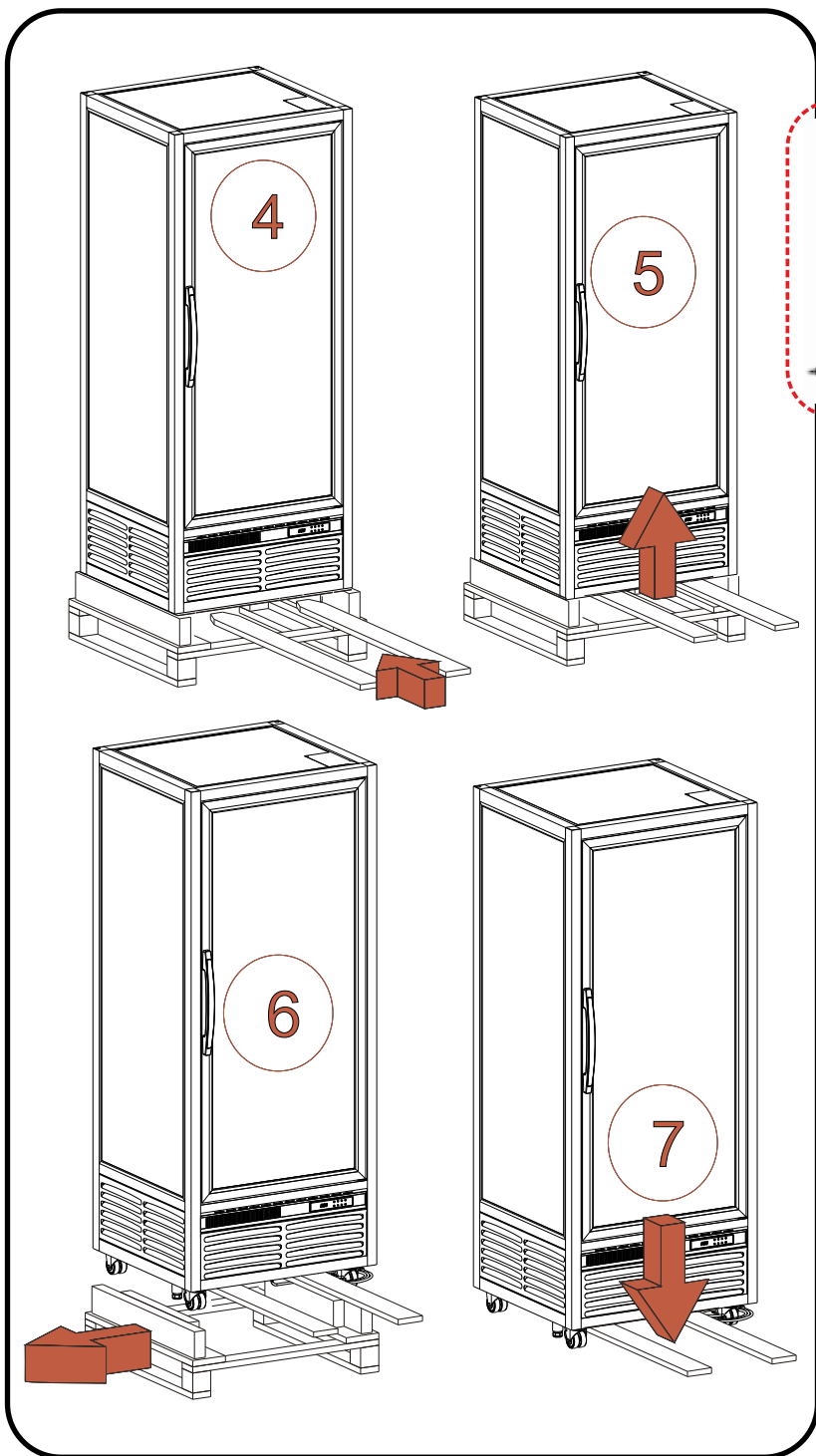
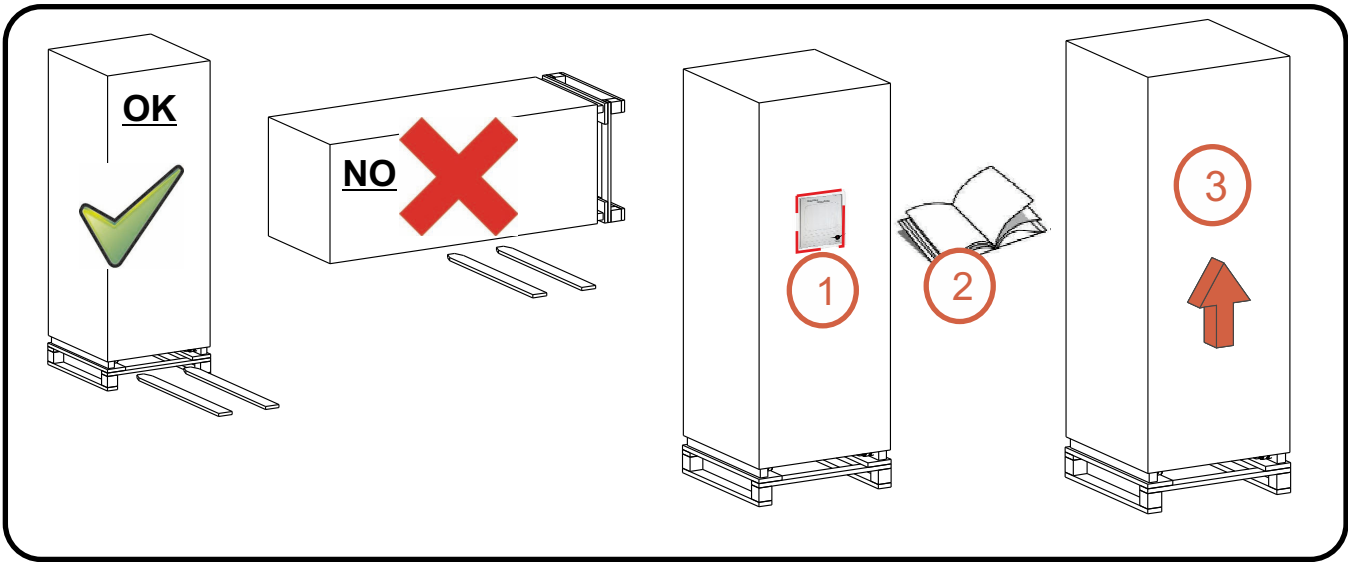

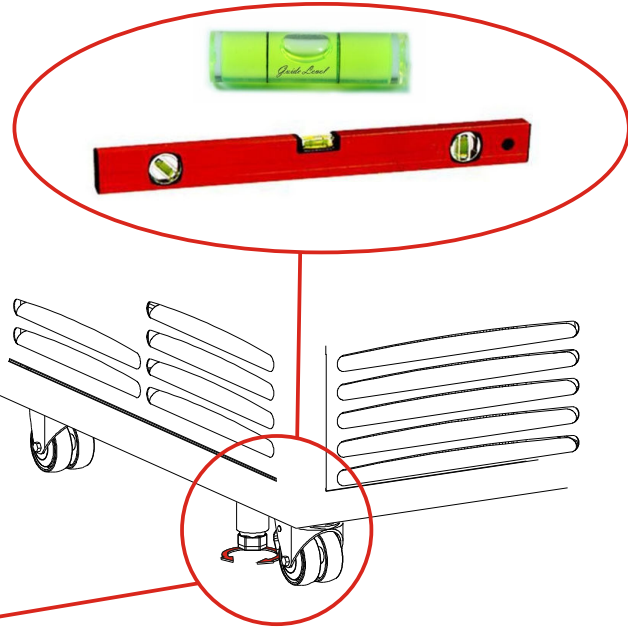
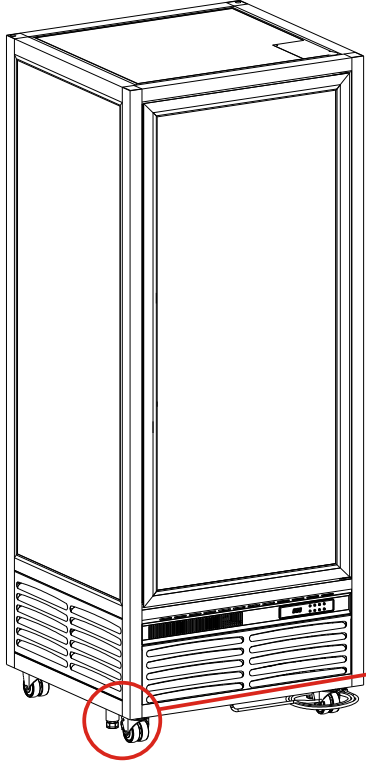
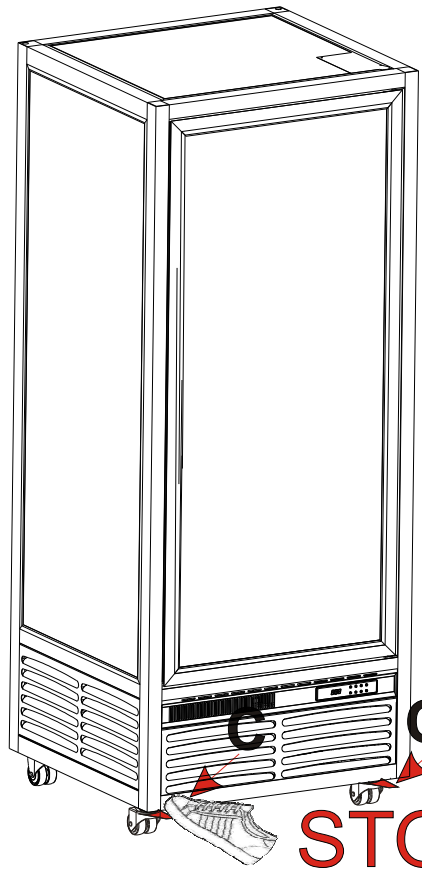
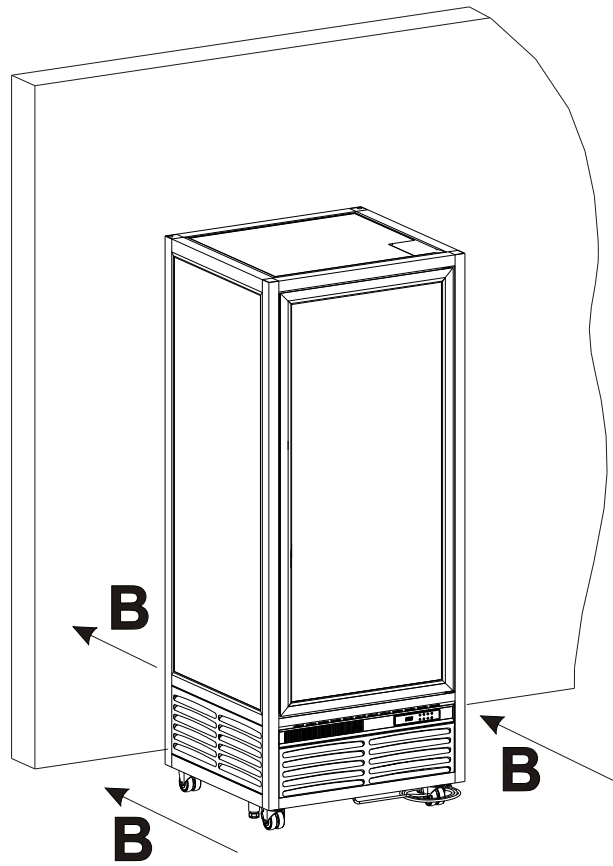

das Schmiermittel
NICHT entfernen
für den ersten Monat
des Lebens.

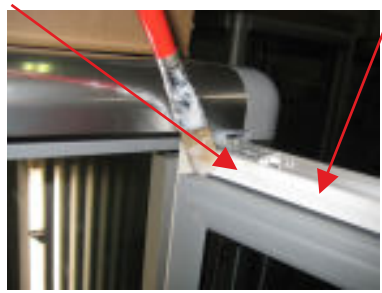

NON rimuovere
il lubrificante
per il primo mese
di vita.
DO NOT remove
the lubricant
for the first month
of life.



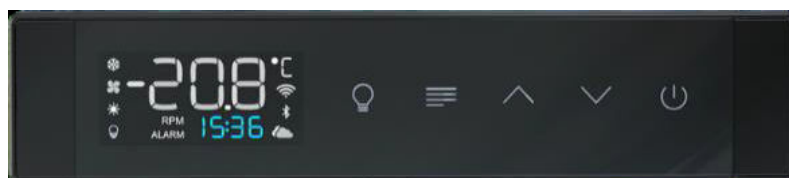
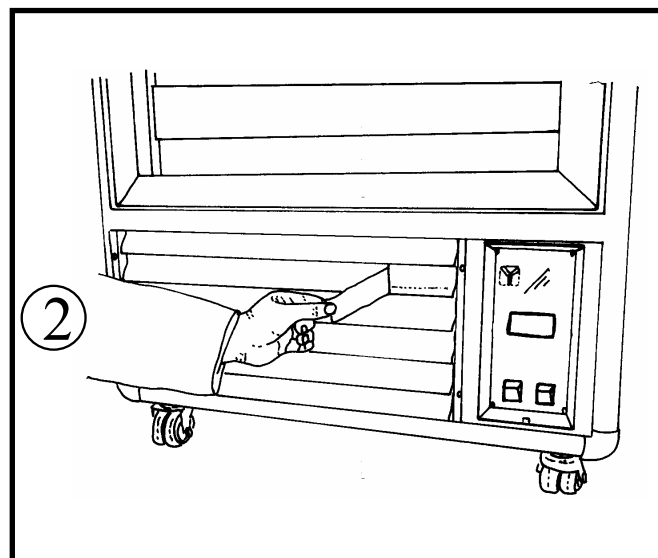
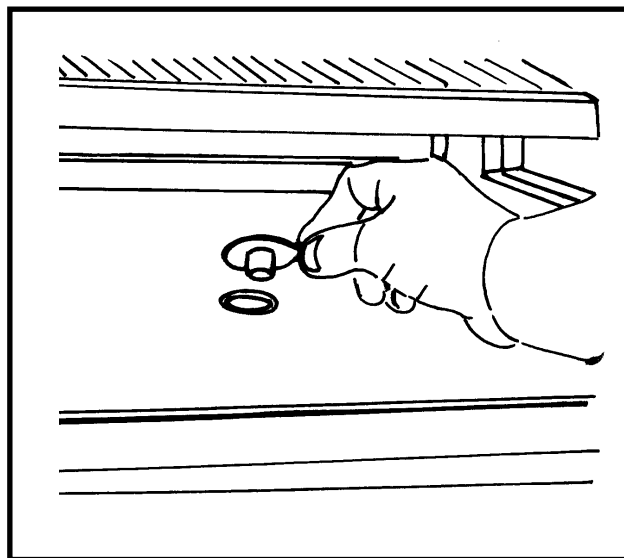
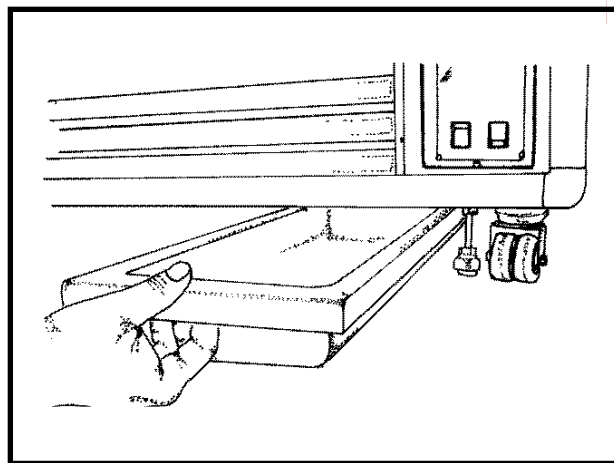
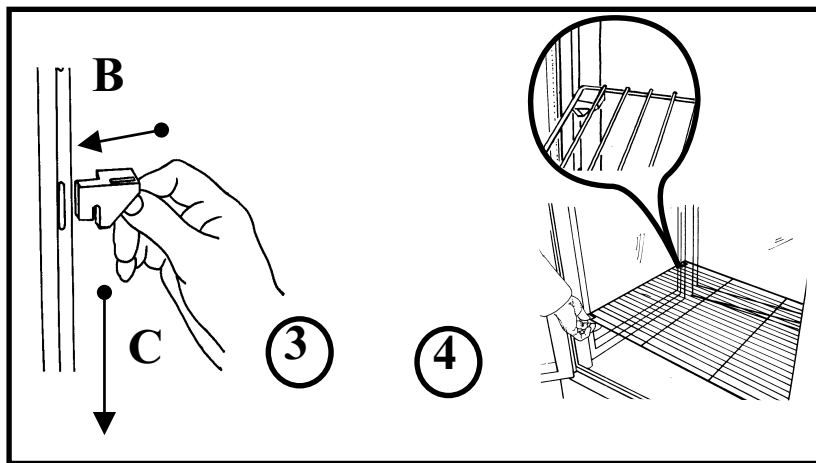

Italiano:
UTILIZZARE IL MANUALE DELLA CENTRALINA (FLEX) CHE TROVATE ALL'INTERNO DELLA VETRINA.

Inglese:
USE THE CONTROL UNIT MANUAL (FLEX) THAT YOU FIND INSIDE THE SHOWCASE.

Tedesco:
BENUTZEN SIE DAS HANDBUCH FÜR DIE STEUER-EINHEIT (FLEX), DAS SIE INNEN DAS GERÄT FINDEN.

Francese:
UTILISEZ LE MANUEL DU RÉGULATEUR (FLEX) QUE VOUS TROUVEREZ À L'INTÉRIEUR DE LA VITRINE.

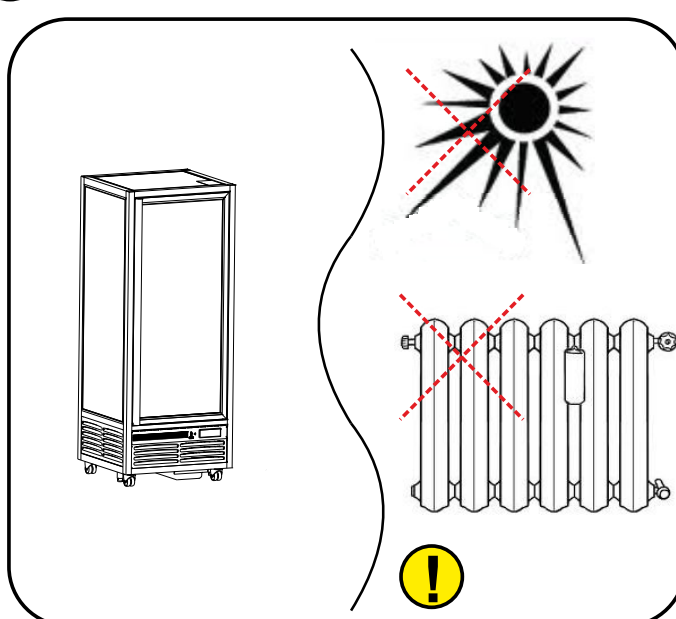
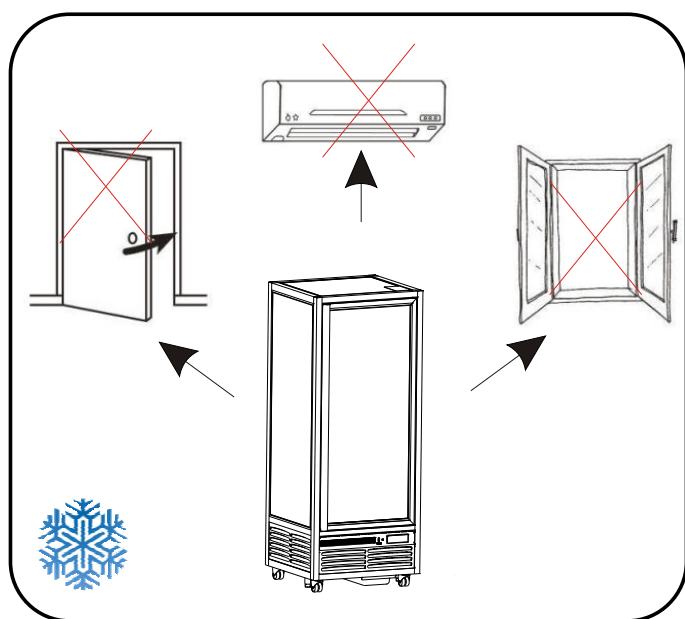
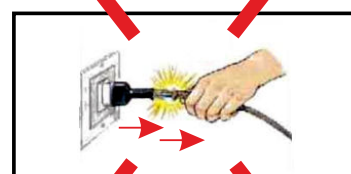
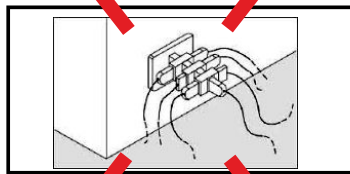
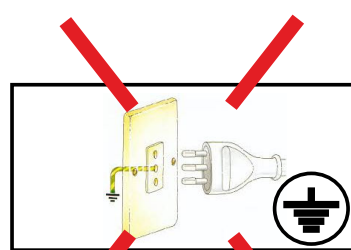
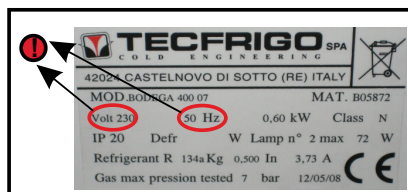
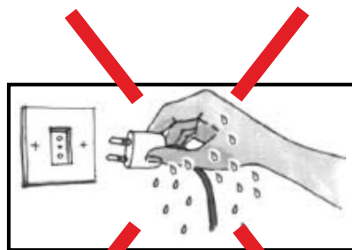

- ❗ Il **non** buon funzionamento della macchina causato da inosservanza di quanto spiegato e/o mostrato in questo manuale, declina ogni tipo di responsabilità per Tecfrigo SPA.
- ❗ Tecfrigo SPA declines any responsibility if the bad performance of the equipment is caused by non compliance to what is shown and/or explained in this manual.
- ❗ Das nicht reibungslose Betrieb des Gerätes, verursacht durch Nichtbeachtung wie in diesem Handbuch dargestellt ist, übernimmt keine Haftung für Tecfrigo Spa.
- ❗ Le mauvais fonctionnement de la machine causés par le non-respect comme expliqué et / ou illustrés dans ce manuel, décline toute la responsabilité de Tecfrigo spa
- ❗ Tecfrigo SPA declina toda responsabilidad si el mal funcionamiento del equipo es causado por el incumplimiento de lo que se muestra y/o se explica en este manual.



❶ BACINELLA DI EVAPORAZIONE AUTOMATICA

La maggior parte delle unità dispone di una bacinella di evaporazione automatica. Anche l'acqua di sbrinamento può causare guasti considerevoli poiché può bucare il tubo che fornisce il calore necessario per l'evaporazione dell'acqua o deteriorare la resistenza elettrica. Quindi si raccomanda di prestare attenzione a questa bacinella e procedere alla sua pulizia periodicamente.

❶ AUTOMATIC EVAPORATION BASIN

The majority of units, have a basin of automatic evaporation. Even the defrost water can cause considerable damage, since it can pierce the tube that provides the heat necessary for the evaporation of water or deteriorate the electrical resistance. So please pay attention to this basin and clean it periodically.

❶ AUTOMATISCHE VERDUNSTUNGSTASSE

Die meisten Einheiten haben eine Tasse mit automatischer Verdunstung. Auch das Tauwasser kann erhebliche Schäden verursachen, da das Rohr dass die notwendige Wärme für die Verdampfung gibt lochen kann oder es zu einer Verschlechterung des elektrischen Widerstandes bringt. Also bitte achten Sie auf diese Tasse und reinigen Sie diese regelmässig.

❶ BENDEJA DE EVAPORACION AUTOMATICA

La mayoría de los equipos disponen de una bandeja de evaporación automática. El agua de deshielo también puede provocar averías de consideración, ya que puede picar la tubería que aporta el calor necesario para evaporar el agua o deteriorar la resistencia eléctrica. Se recomienda pues, prestar atención a esta bandeja y proceder a su limpieza con periodicidad.

❶ PLATEAU D'ÉVAPORATION AUTOMATIQUE

La majorité des appareils disposent d'un plateau d'évaporation automatique, L'eau du dégivrage peut également occasionner des pannes importantes, étant donné qu'elle peut percer la tuyauterie qui apporte la chaleur nécessaire permettant l'évaporation de l'eau ou encore abimer la résistance électrique. Il est recommandé de prendre soin de ce plateau et de le nettoyer périodiquement.

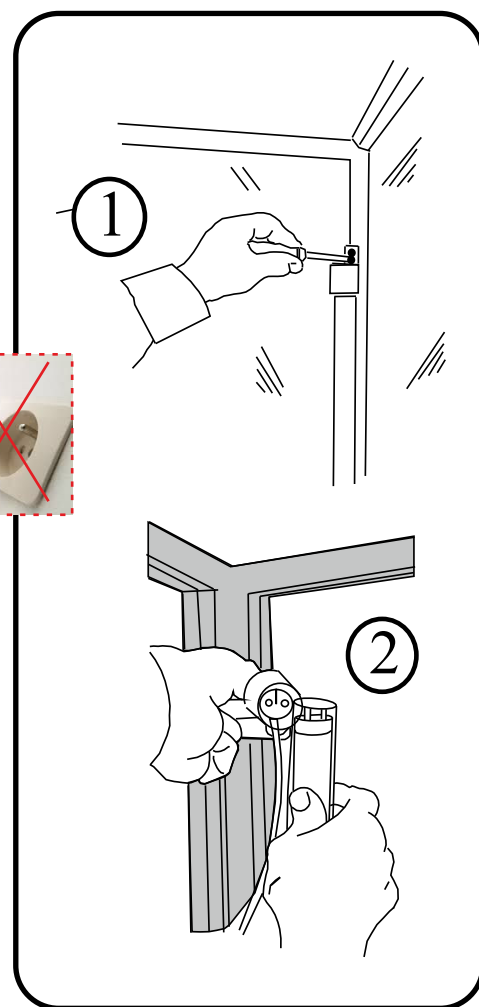
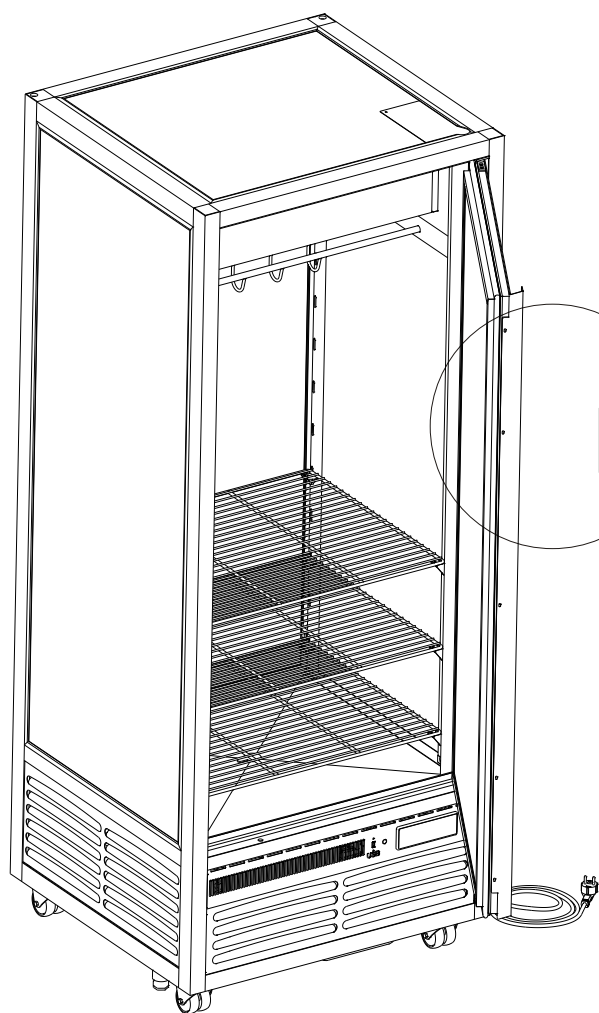

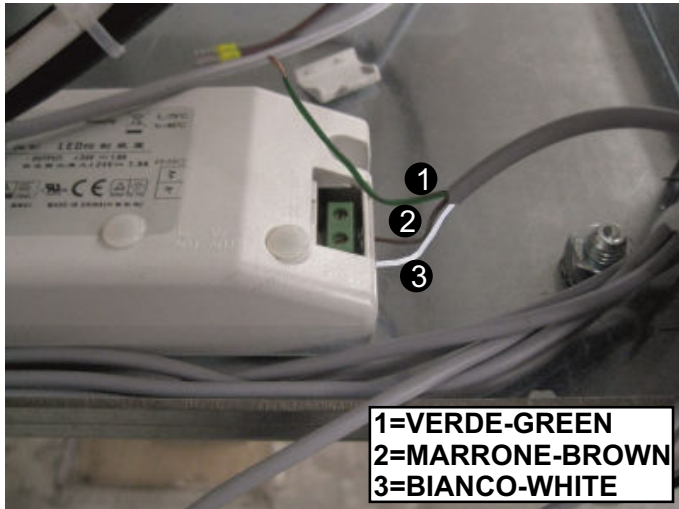

LUCE CALDA
WARM LIGHT

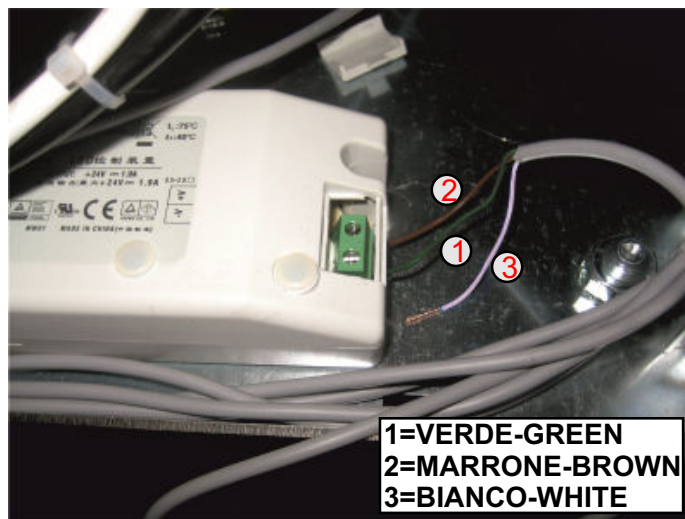

LUCE FREDDA
COOL LIGHT

potenziometro
(optional)

potentiometer
(optional)



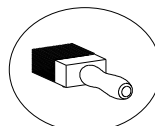
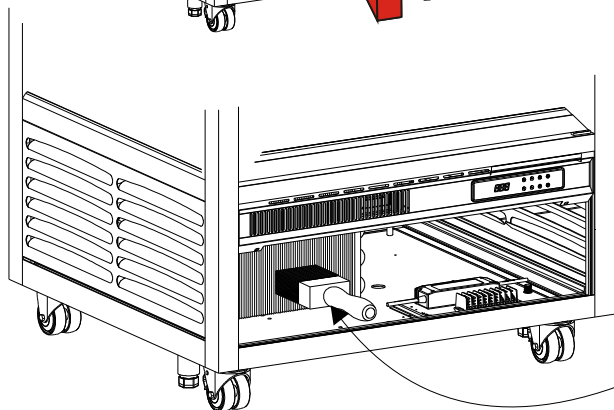
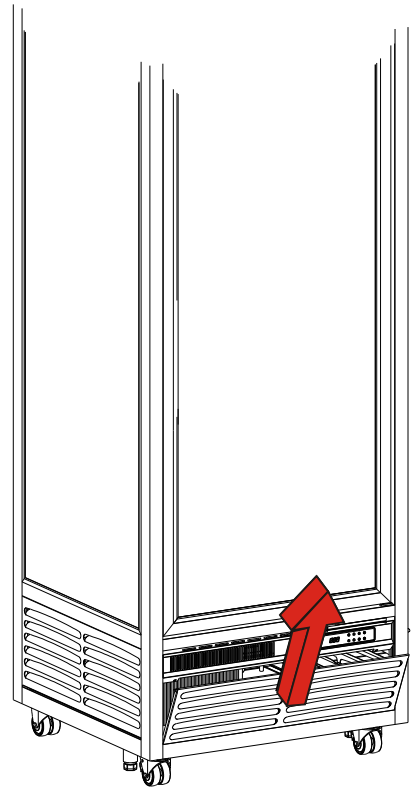
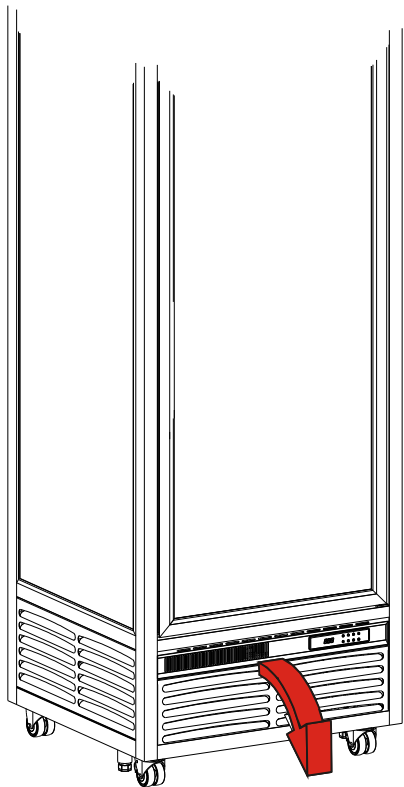
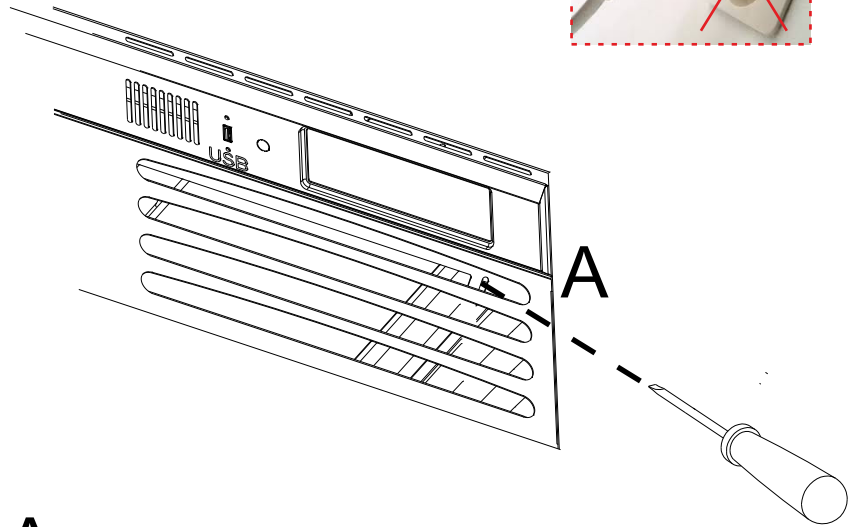
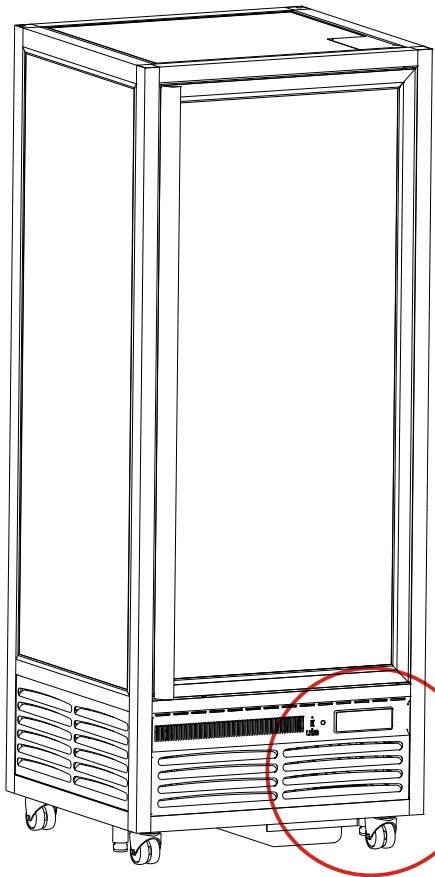

- ⚠️ Almeno una volta al mese
- ⚠️ At least once a month
- ⚠️ Mindestens einmal pro Monat
- ⚠️ Por lo menos una vez al mes
- ⚠️ Au moins une fois par mois



Montaggio della maniglia Assembly of the handle

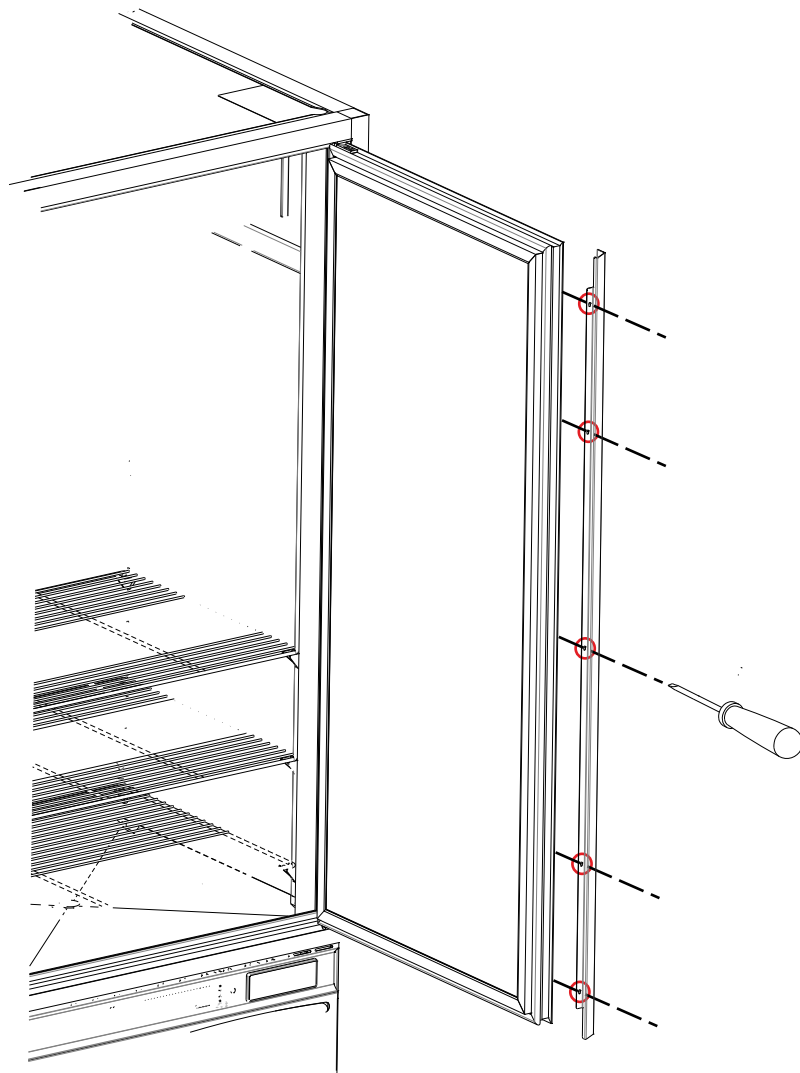

- Se il cavo di alimentazione è danneggiato, deve essere sostituito dal produttore, dal suo centro di assistenza o da personale qualificato per evitare rischi
- If the supply cord is damaged, it must be replaced by the manufacturer, its service agent, or similarly qualified persons in order to avoid a hazard.
- Wenn die Anschlussleitung beschädigt ist, darf sie nur von einem autorisierten Kundendienst ausgetauscht werden, um Gefahr zu vermeiden.

- Si le câble d'alimentation est endommagé, il doit être remplacé par le fabricant, des représentants ou des professionnels agréés afin d'éviter les dangers.
- Si el cable de alimentación está dañado, debe ser reemplazado por el fabricante, por su Centro de servicio o personal calificado para evitar riesgos



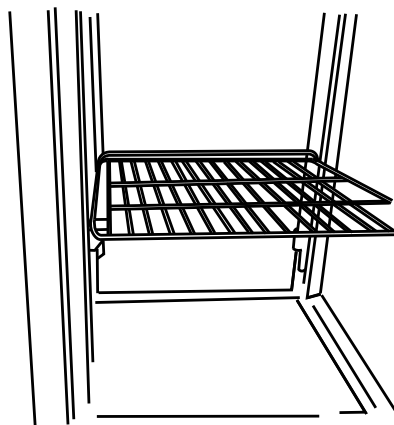

Attenzione, non riempire completamente i ripiani espositivi per consentire un corretto deflusso dell'aria fredda interna.

Attention: do not fill up completely the exposition shelves in order to permit a correct internal cold air flow

Achtung: Fuellen Sie bitte die Expositions Regale nicht komplett auf, um eine korrekte Zirkulierung von kalter Luft zu haben

Attention: ne pas remplir complètement les étagères expositives pour permettre un écoulement correct de l'air froide interne.

Cuidado: no llenar totalmente los estantes exposidores para permitir un correcto flujo de aire frio interior.





I

1) Compressore 2) Condensatore 3) Comando cupola - interruttore 4) Evaporatore 5) Filtro 6) Interruttore 8) Morsettiera 9) Motoriduttore 10) Illuminazione 11) Alimentatore 12) Sonda 13) Spina 15) Termostato 16) Ventilatore condensatore 17) Reattore 18) Starter 19) Ventilatore 20) Valvola solenoide 21) Resistenza 22) Trasformatore 23) Display 24) Microinterruttore 25) Resistenza scarico 26) Umidostato 27) Relè 28) Galleggiante 29) Sirena 30) Potenziometro 31) Scheda LED 32) Sonda umidità 33) Scheda WIFI 34) Antenna 35) Elettroserratura 36) Porta USB 37) Inverter 38) Controllo valvola elettronica 39) Valvola elettronica 40) Sonda valvola elettronica 41) Trasduttore 42) Ricevitore 43) Valvola termostatica 47) Lampada (UV) 48) Teleruttore 49) Lampade IR

UK

1) Compressor 2) Condenser 3) Cover control 4) Evaporator 5) Filter 6) Switch 8) Terminal board 9) Motor reducer 10) Lighting 11) Power supply unit 12) Probe 13) Plug 15) Thermostat 16) Condenser fan 17) Reactor 18) Starter 19) Fan 20) Solenoid valve 21) Resistor 22) Transformer 23) Display 24) Microswitch 25) Resistance (discharge) 26) Humidity controller 27) Relay 28) Float 29) Alarm 30) Potentiometer 31) electronic card (LED) 32) Probe (humidity) 33) WIFI- Card 34) Aerial 35) Electric lock 36) USB port 37) Inverter 38) Controller for the electronic valve 39) Electronic valve 40) Electronic valve probe 41) Transducer 42) Receiver 43) Thermostatic valve 47) Lamp (UV) 48) Remote switch 49) IR lamps

D

1) Kompressor 2) Verflüssiger 3) Steuerung Kuppel 4) Verdampfer 5) Filter 6) Schalter 8) Klemmleiste 9) Getriebemotor 10) Beleuchtung 11) Netzteil 12) Sensor 13) Netzsteckdose 15) Thermostat 16) Gebläse Verflüssiger 17) Reaktionsapparat 18) Starter 19) Ventilator 20) Solenoidventil 21) Widerstand 22) Transformator 23) Anzeige 24) Mikroschalter 25) Widerstand (Entladung) 26) Feuchtigkeit Steuerpult 27) Relais 28) Schwimmer 29) Alarm 30) Potentiometer 31) Elektronische Karte (LED) 32) Sonde (Luftfeuchtigkeit) 33) elektronische Karte (WIFI) 34) Antenne 35) Elektroschloss 36) USB-Port 37) Wandler 38) Elektronische Ventilsteuerung 39) Elektronisches Ventil 40) Elektronische Ventilsonde 41) Wandler 42) Empfänger 43) Thermostatventil 47) Lampe (UV) 48) Fernschalter 49) IR-Lampen

E

1) Compresor 2) Condensador 3) Mando campana 4) Evaporador 5) Filtro 6) Interruptor 8) Caja de bornes 9) Motorreductor 10) Iluminación 11) Alimentador 12) Sonda 13) Enchufe 15) Termostato 16) Ventilador condensador 17) Reactor 18) Dispositivo de arranque 19) Ventilador 20) Válvula solenoide 21) Resistencia 22) Transformador 23) Monitor 24) Microinterruptor 25) Resistencia (descarga) 26) Regulador de la humedad 27) Relé 28) Flotador 29) Alarma 30) Potenciómetro 31) Tarjeta electrónica (LED) 32) Sonda (humedad) 33) Tarjeta (WIFI) 34) Antena 35) Cerradura eléctrica 36) Puerto USB 37) Inversor 38) Controlador de válvula electrónica 39) Valvula electronica 40) Sonda de la válvula electrónica 41) Transductor 42) Receptor 43) Válvula termostática 47) Lámpara (UV) 48) Telerruptor 49) Lámparas IR

F

1) Compresseur 2) Condenseur 3) Commande vitrine bombée 4) Évaporateur 5) Filtre 6) Interrupteur 8) Bornier 9) Motoréducteur 10) Éclairage 11) Alimentateur 12) Sonde 13) Prise de courant 15) Thermostat 16) Ventilateur condenseur 17) Réacteur 18) Starter 19) Ventilateur 20) Soupape solénoïdale 21) Résistance 22) Transformateur 23) Afficher 24) Microinterrupteur 25) Résistance (décharge) 26) Contrôleur d'humidité 27) Relais 28) Flotteur 29) Alarme 30) Potentiomètre 31) Conseil (LED) 32) Sonde (humidité) 33) Carte (WIFI) 34) Antenne 35) Serrure électrique 36) Port usb 37) Onduleur 38) Contrôleur de vanne électronique 39) Valve électronique 40) Sonde de la vanne électronique 41) Transducteur 42) Récepteur 43) Vanne thermostatique 47) Lampe (UV) 48) Télerrupteur 49) Lampes IR



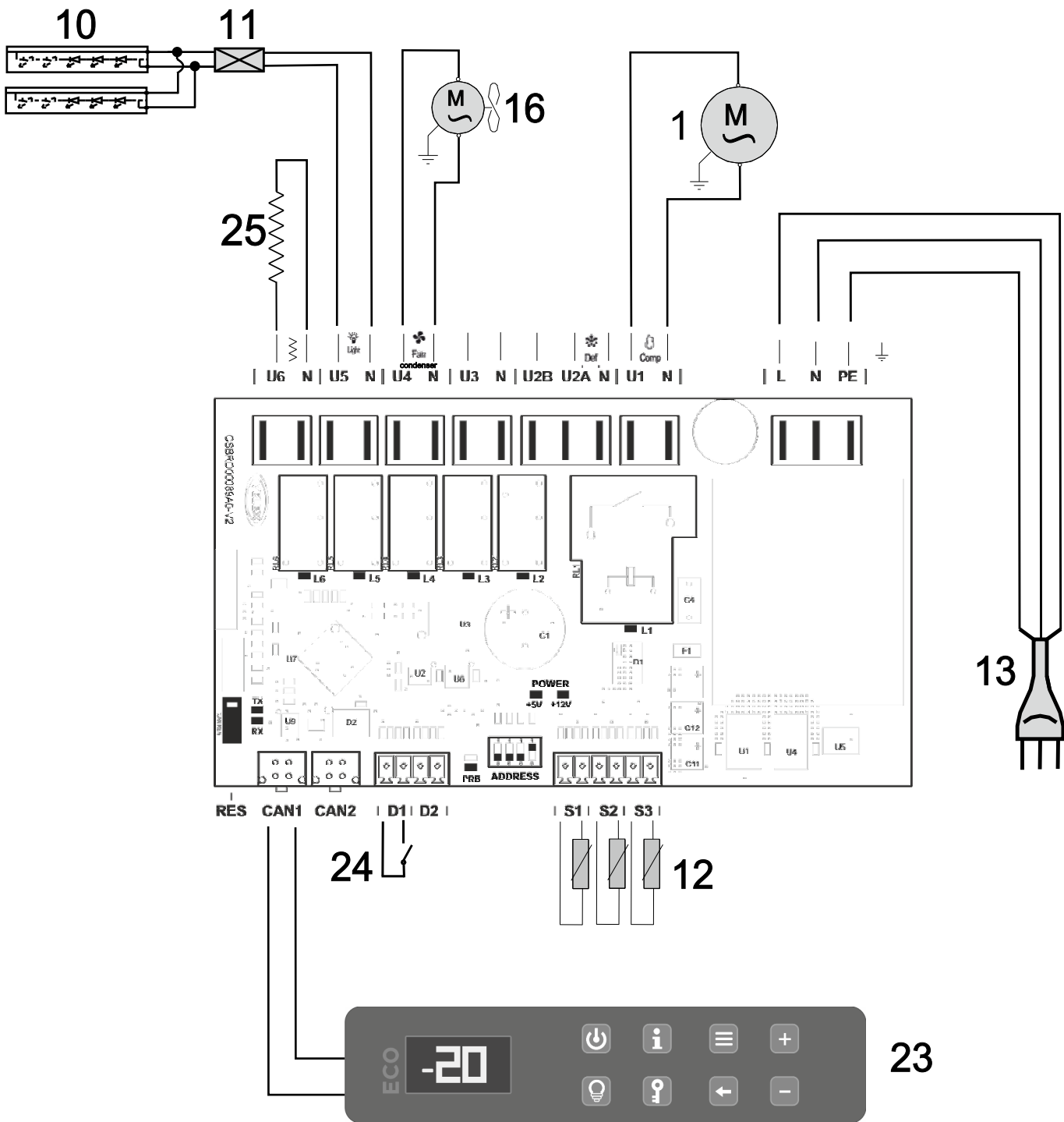

MEAT
275-6
301-2
551-2
R290(ECO6)



MEAT 1551 /2 R290(ECO6)

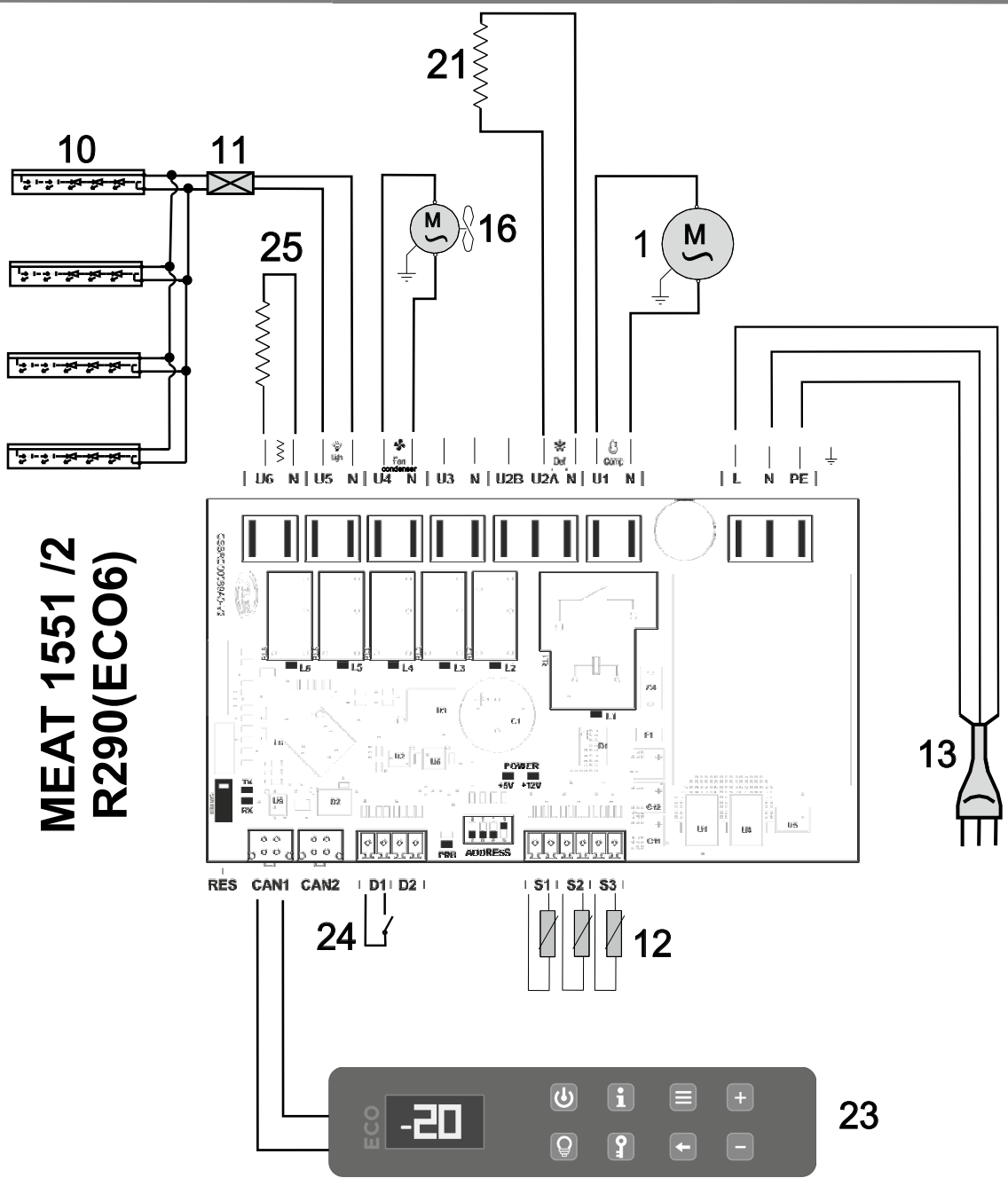

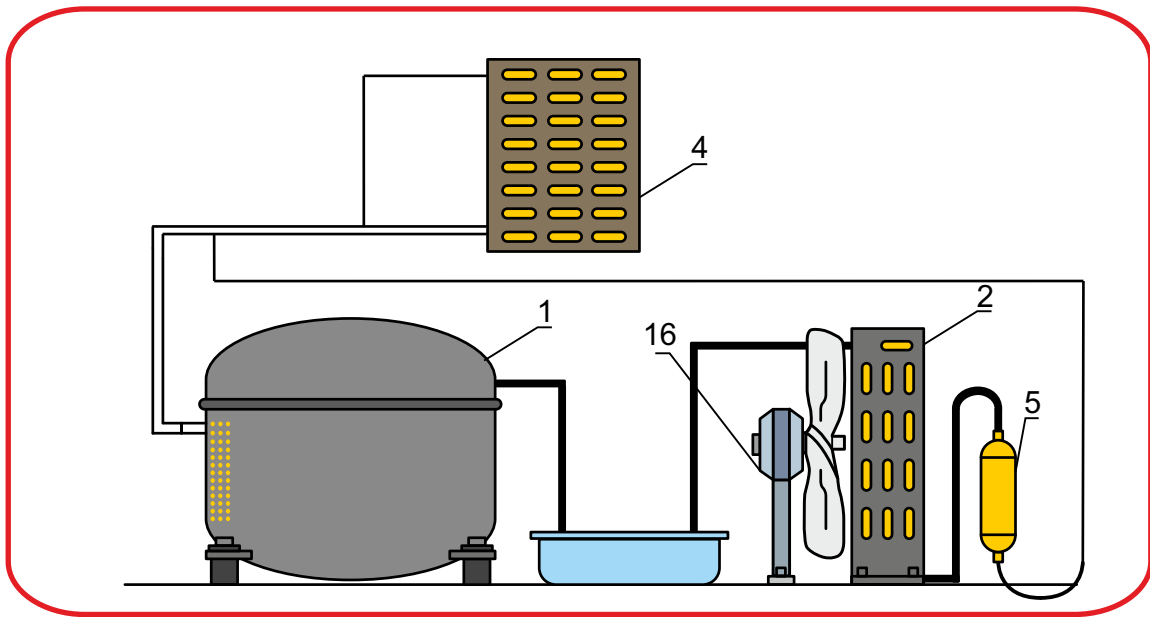

La presenza di gas R290/R600a è contrassegnata dal simbolo:



The presence of R290/R600a gas is marked by the symbol:



La présence de gaz R290/R600a est marquée par le symbole:



Das Vorhandensein von R290/R600a Gas ist durch das Symbol gekennzeichnet:



La presencia de gas R290/R600a esta' marcada por el simbolo:





COLD
ENGINEERING
TECFRIGO

TECFRIGO s.p.a.
42024 Castelnovo di Sotto
(Reggio Emilia) Italy
Via Galileo Galilei, 22
Tel. 0522.683246 / 0522.688443
Fax Uff. amm. 0522.688444
e-mail: info@tecfrigo.com
<http://www.tecfrigo.com>



Management
System
ISO 9001:2015



www.tuv.com
ID 9105015489



COLD
ENGINEERING
TECFRIGO

