

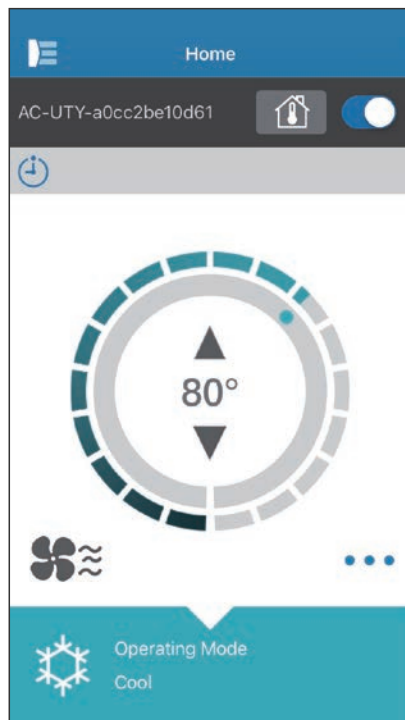

OPERATING MANUAL

Wireless LAN control for air conditioner



PART No. 9382385002-04

FUJITSU GENERAL LIMITED

You can control your air conditioner (as “A/C”) from outside the room or from a distant location through wireless LAN connection.*1

You can change various functions*2 of the air conditioner.

The operating status will be shown on your smartphone or tablet PC screen*3.

FGLair Mobile application (as “mobile app”) allows easy access and easy control.

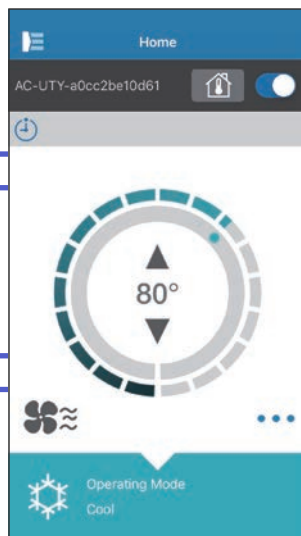

NOTES:

- *1: FGLair compatible air conditioner with W-LAN adapter (as “this product”) is necessary.
- *2: Usable functions may differ with each air conditioner model. Please refer to the operating manual of your air conditioner for details.
- *3: The display contents are subject to change as a result of updates in the mobile app, and may not match the actual screen.

CONTENTS.....	En-02
PREPARATION.....	En-03
SAFETY PRECAUTIONS.....	En-04
USAGE PRECAUTIONS.....	En-05
WIRELESS LAN USAGE PRECAUTIONS.....	En-07
IMPORTANT TIPS.....	En-10
USER REGISTRATION.....	En-13
AIR CONDITIONER REGISTRATION.....	En-16
HOME MENU.....	En-17
SIDE MENU.....	En-19
OPERATING THE AIR CONDITIONER.....	En-31
ICON DETAILS.....	En-36
TROUBLESHOOTING.....	En-38
ERROR HISTORY (For Authorized service personnel only.).....	En-48

Items to check

Please prepare the following items before using this product.

Air conditioner	FGLair compatible air conditioner with W-LAN adapter	
Wireless Router	This product uses a wireless router that supports IEEE802.11 b/g/n wireless LAN standard. Set the connection to the wireless router with WPS to perform communications by wireless LAN. Refer to the operating manual of the wireless router you wish to use, if it supports IEEE802.11b/g/n or WPS.	
Smartphone or Tablet PC	Supported OS: • Android OS • iOS	Please check the latest supported OS version at Google play or App store.
Documents	Setting manual for Wireless LAN control Operating manual of indoor unit	



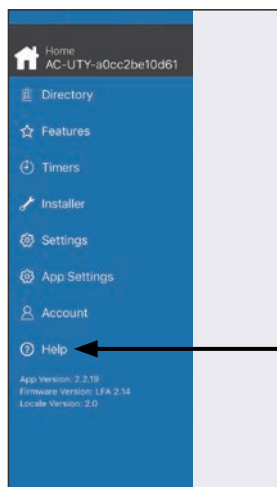

Android and Google Play are registered trademarks of Google Inc.
App store is a service mark of Apple Inc., registered in the U.S. and other countries.
IOS is a trademark or registered trademark of Cisco in the U.S. and other countries and is used under license.

Side menu



For more information on Wireless LAN control, please refer to the [Help] page from the side menu or see the following website;
www.fujitsu-general.com/global/support/

- ◆ To prevent personal injury, or property damage, read this section carefully before you use this product, and be sure to comply with the following safety precautions.
- ◆ Incorrect operation due to failure to follow the instructions may cause harm or damage, the seriousness of which is classified as follows:

 WARNING	This mark indicates procedures which, if improperly performed, might lead to the death or serious injury of the user.
 CAUTION	This mark indicates procedures which, if improperly performed, might possibly result in personal harm to the user or damage to property.
 This mark denotes an action that is PROHIBITED .	 This mark denotes an action that is COMPULSORY .

 **WARNING**

● When you use this product, it will become possible to operate the air conditioner from locations where you cannot see it directly. This means that people in the room may be exposed to the unintended operation of the air conditioner. Check the condition of the room before using this product.

- **Be sure to check on a regular basis that the power supply to the air conditioner is securely connected, and that dust has not built up in the surrounding area.**
It may cause heating, or fire.
- **Be sure to check in advance that there are no malfunctions of the air conditioner.**
- **Be sure that the airflow from the air conditioner will not cause any adverse effects.**
Objects may fall down causing personal injury, fire, or damage to property.
- **If you know that there are people in the vicinity of the air conditioner, inform them in advance that you will be operating and stopping it from a distant location.**
Sudden operation or stopping of the air conditioner may surprise a person and cause the person to fall down or tumble if the person is on a stand. Furthermore, rapid changes in the room temperature may cause deterioration in a person's physical condition. Do not use this product when there are people in the room who are not able to control the temperature by themselves (For example, infants, children, those with physical disabilities, elderly or sick persons.).
- **Fully understand the reserved timer settings and other operations before using this product.**
Unexpected operation or stopping of the air conditioner may cause deterioration in a person's physical condition or an adverse effect on animals or plants.
- **Frequently check the settings and operating situation of the air conditioner when using this product from a distant location.**
Rapid changes in the room temperature may cause deterioration in a person's physical condition or an adverse effect on animals or plants.

- If you operate the air conditioner from this product, the indicator lamps on the indoor unit will light up, but the lamps will not flash nor will there be any reception sounds from the indoor unit.
- If there is bad reception between this product and the wireless router, adjusting the wireless router position or direction of the antenna may improve the reception. It may also be possible to improve reception by moving the wireless router closer to this product or using a wireless LAN repeater.

When you use a wireless LAN, there are precautions that you must follow in relation to radio waves, personal information, and so on. To use this product correctly, be sure to read the following precautions and the operating manual of the wireless LAN equipment you are using. We will assume no responsibility, unless legal liability is recognized, in regards to failures, other defects and damages incurred by use of this product that occur through incorrect use or during use by yourself or a third party.

Radio Wave Usage Precautions

- Do not use this product in the following locations. Using this product in such locations may cause communications becoming unstable or not possible.
 - Near wireless communication equipment that uses the same frequency band (2.4GHz) as this product.
 - Places where there are magnetic fields from equipment such as microwave ovens, or static electricity or radio wave interference occurs. (Radio waves may not reach depending on the environment.)

Personal Information (Security-related) Usage Precautions

- There is a possibility of interception if you use wireless LAN equipment due to the use of radio waves regardless of whether you use encryption or not.
- Wireless LAN uses radio waves to exchange information between this product and the wireless router. This means it has the advantage of freely being able to make a LAN connection if within reach of radio waves. On the other hand, if the radio waves are within a certain range, they will reach all locations beyond obstacles (e.g. walls). Therefore, it is possible your communications may be intercepted and read or illegally intruded upon.
- Do not connect to equipment and networks which you are not authorized to use when setting up your wireless connection.
- Initialize the settings of this product when disposing it, or transferring it to a third party.

Others

- Use this product as regular wireless LAN equipment.
 - Do not use this product in hospitals or in/near locations with medical equipment.
 - Do not use this product within aircraft.
 - Do not use this product near electronic equipment that handles high-precision control or weak signals.

Examples of electronic equipment to be careful of:

Hearing aids, pacemakers, fire alarms, automatic doors and other automatic control equipment.

- This is not a guarantee of wireless connection and performance with all wireless routers and in all residential environments. Radio waves may not reach or may be interrupted in the following situations.
 - Use in buildings made from concrete, rebars or metal.
 - Installation near obstacles.
 - Interference with wireless communication equipment using the same frequency.
 - Places where there are magnetic fields from equipment such as microwave ovens, or static electricity or radio wave interference occurs.

- Set up this product and install the mobile app only after reading the operating manual of the wireless router.

About this manual

This manual explains how to use the mobile app to control this product. For details on how to connect your air conditioner to your wireless LAN network, please refer to the online manual.

Internet access

To use this mobile app, Internet access is necessary.

Please confirm that the connection to the wireless LAN network is strong and will not break during setting.

- The air conditioner settings from the mobile app will not be reflected in the wireless remote controller.
- It will not be possible to give operation instructions or carry out monitoring from the mobile app while the power supply is disconnected from the air conditioner (via breaker or plug).
- The room temperature will be displayed in the mobile app during operation. However, the displayed room temperature may not be correct depending on the situation in the room, or the air conditioner operating status. Use this only as a reference.
- If the mobile app and remote controller settings differ, the latest operation performed will take priority.
 - * If timer settings are done from the mobile app and from the wireless or wired remote controller, both timer settings will be active.

Others

Name of parts (Air conditioner side)

For W-LAN adapter with SSID which start with "AC-UTY-".

Wireless LAN indicator and button on front panel (for built-in products)

Wireless LAN indicator and button on W-LAN adapter (for option)

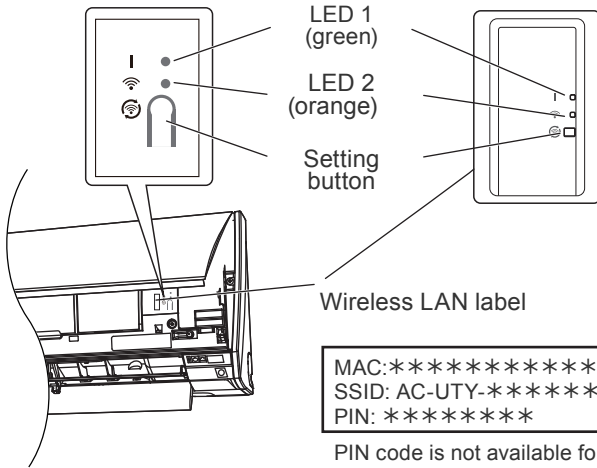

Sleep mode**

*Lighting pattern: ○ Off ● On Flashing

When the W-LAN adapter is not used

- The W-LAN adapter will turn to Sleep mode when the W-LAN setup is not completed within an hour after the power supply is connected to the air conditioner (via breaker or plug).
- The W-LAN adapter cannot be used during Sleep mode. The W-LAN adapter will be nonfunctional, and both LED will be off.

To use the W-LAN adapter

- Press the Setting button of the W-LAN adapter. Confirm that the LED lighting has changed.

**For products with Sleep mode only. Refer to the setting manual to see if it applies to your W-LAN adapter.

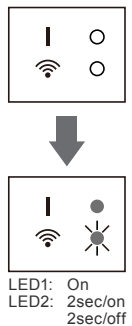

For W-LAN adapter with SSID which start with “AP-”.

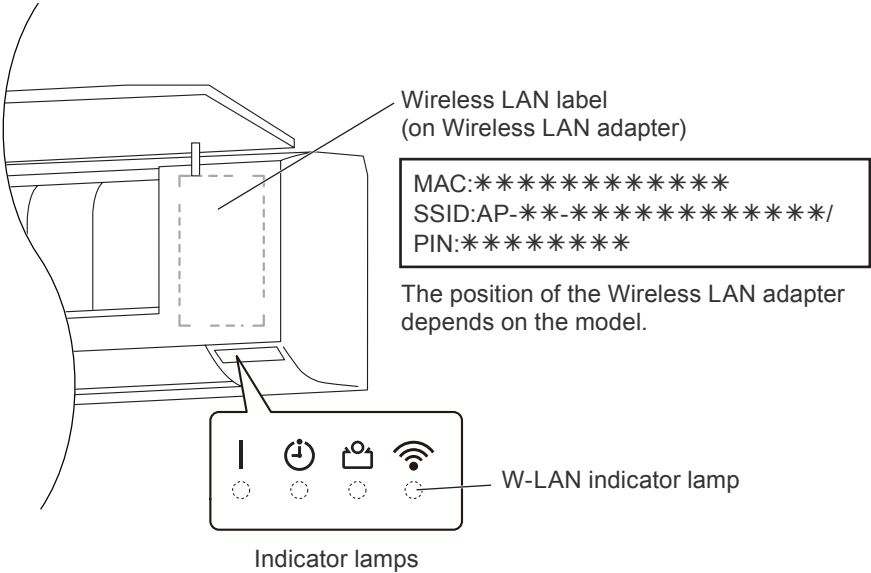







Selecting the world region

Select World Region

Please select the world region where you will be using FGLair. In order to successfully complete the registration of air conditioners, please set the World Region correctly



Confirm

	Ivory Coast
	Jamaica
	Japan
	Jersey
	Jordan
	Kazakhstan

After launching the mobile app, please select the region of installment from the list.

To set, tap [Confirm].

This setting can also be done from the “Signing in” page.

NOTES:

- Please select the region before creating an account.
If you create an account beforehand, you may not be able to sign in. In this case, please create your account again.
- If you do not set the region correctly, you will not be able to register the air conditioner.

Signing in

Email Address

Password

Sign In

Forgot Password?

Re-send Email Confirmation?

Create Account

After selecting the region, please sign in from this page.

To create a new account, tap [Create Account] and follow the procedures in the following pages.

If you already have an account, sign in with the email address and password you have registered.

If you have forgotten your password, tap here. Enter your email address in the following pages to receive an email to reset your password.

You can reset the region by tapping here.

NOTES:

- Reset the region only if you have set the wrong region in the previous page. If you do not set the region correctly, you will not be able to register the air conditioner.
- Please select the region before creating an account. If you create an account beforehand, you may not be able to sign in. In this case, please create your account again.

Create an account

< FGLair Create Account

First Name

Last Name

Email Address

Password

Confirm password

United States

+1

Telephone

[Terms of use is available here](#)

By clicking this box, you agree to be bound by the Terms of Service, and additional terms and conditions provided by third party application stores (including, without limitation, Apple App Store and Google Play)

By clicking this box, you agree to the collection, use and disclosure of your Personal Information as described in the Privacy Policy, including the transfer of your Personal Information to our affiliate in Japan, which will use and protect your Personal Information in accordance with this Privacy Policy.

Sign up

Scroll screen

Enter your email address, password and other information as shown, then tap the box if you agree with the Terms and Conditions. (Approval is necessary to use this mobile app.)

A confirmation message will be sent to the email address you have registered.

To complete creating an account, tap the link in the confirmation message.

Tap here to accept.

NOTES:

- You can only register 1 Email address and password per W-LAN adapter. Use the same Email address and password for other users to operate through the same W-LAN adapter.
- Please use an email address that you can access by smartphone or tablet PC.

Adding new air conditioners

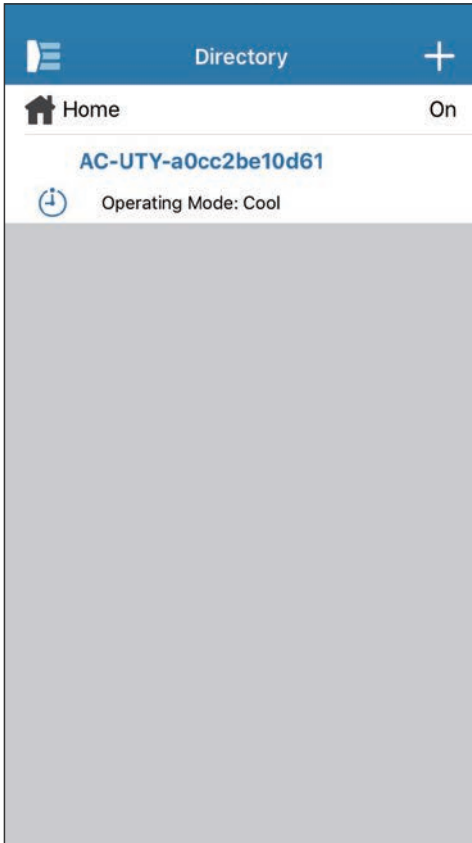

Add a new air conditioner to your mobile app by tapping [+]. Refer to the online manual for details.

<How to access the online manual>

- 1** Sign in to the mobile app.
- 2** Open the side menu then tap [Help].
- 3** Tap [W-LAN Support].

Individual A/C screen



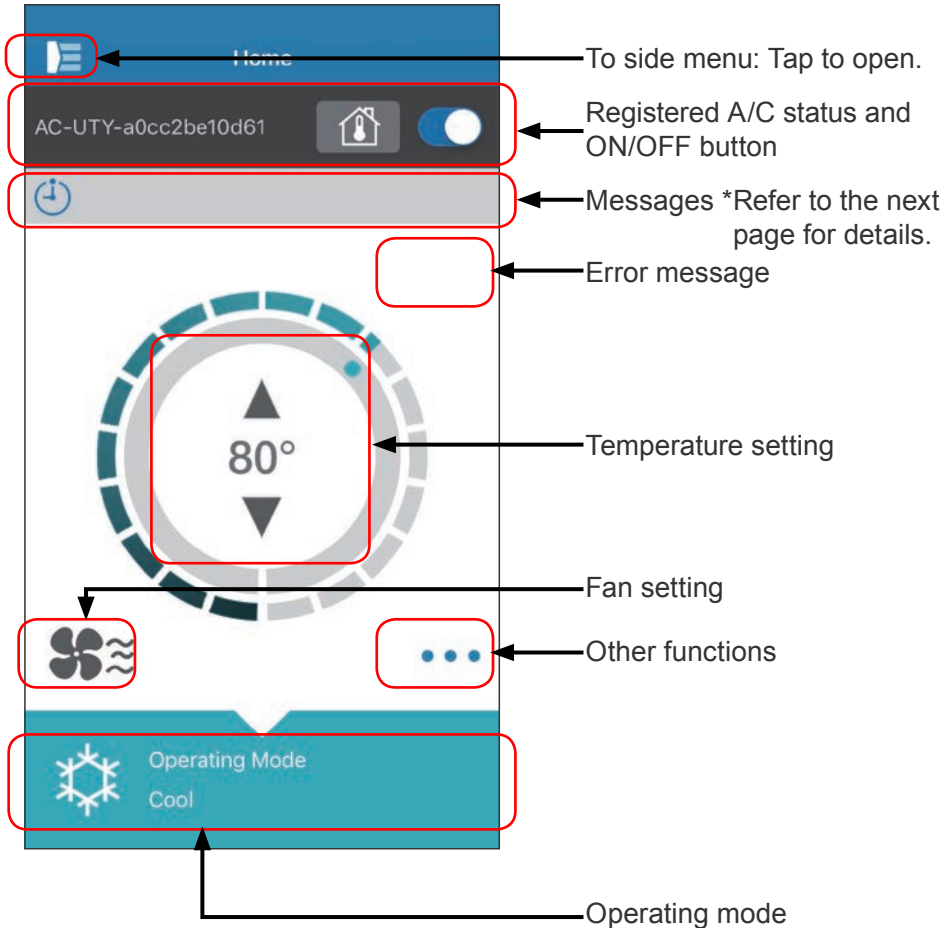







This is the main screen for each air conditioner connected.



NOTES:

Status of the individual air conditioner will be updated to the current condition when the mobile app is active.

Messages

Icon	Description
	Error Message *This icon will appear on the right-hand corner.
	Timers
	Prohibited
	Defrost
	Oil Recovery
	Pump Down or Check Startup or Maintenance
	Mode Mismatch
	Demand Control
	Filter Sign
	Defrost or Oil recovery or Mode mismatch

Each icon signifies a certain message.

When the message icon appears on the screen, tap the icon for details.

*For details on each icon, refer to the “ICON DETAILS”

NOTES:

Depending on your air conditioner, some functions may not appear on the screen.

Pull this menu screen from the side of the Home menu.

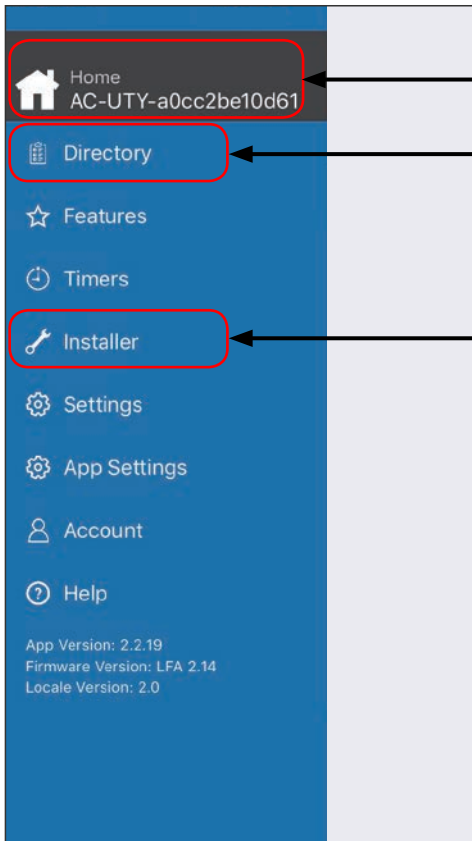

Tap to go to Home menu

Tap to go to Directory

For use by service personnel only.

Various settings can be made from the side menu.

>Side menu>Directory screen

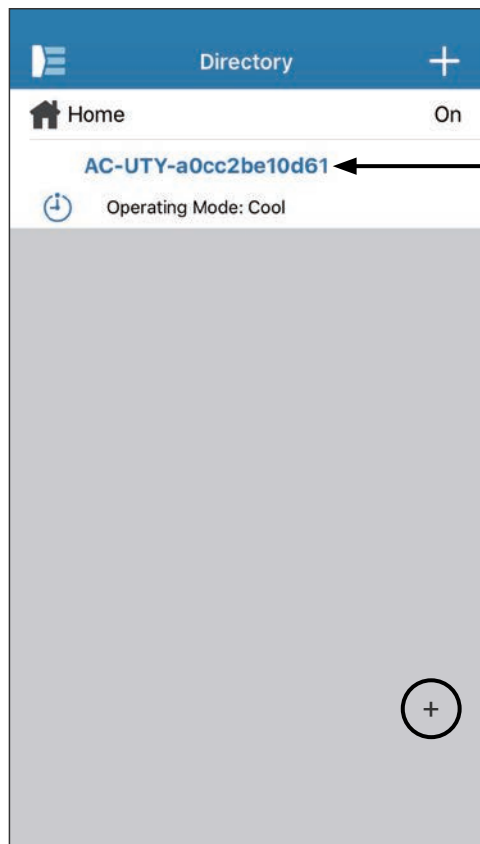

Status of each connected air conditioner will appear.
(On/Off, Operation Mode, Timer, Error)

Tap here to go to the Home menu of each air conditioner.

If you cannot find the air conditioner you wish to control in the list, please refer to the online manual for how to connect the air conditioner via wireless LAN.

>Side menu>Features menu

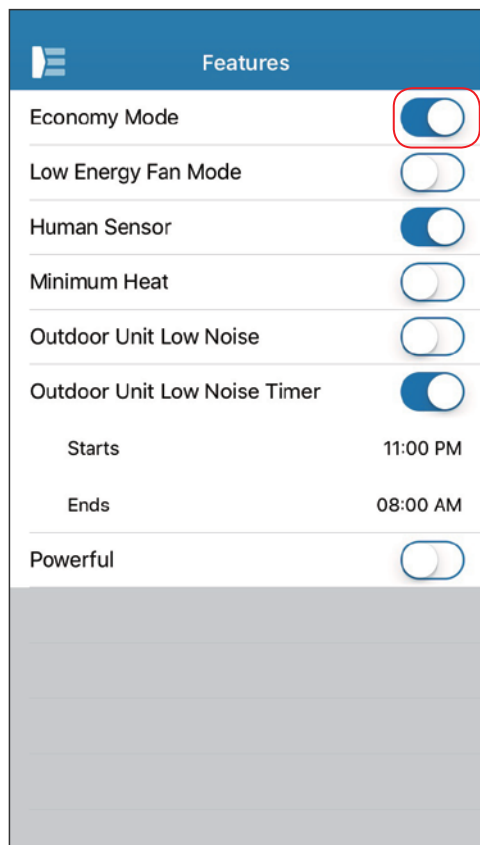

You can set each feature by tapping on the status button on the right hand side.

Off (white): left-side

On (blue): right-side

Outdoor Unit Low Noise Timer

- How to activate
Change status from Off→On.
Set the starting time (Starts) and ending time (Ends).
- How to deactivate
Change status from On→Off.

NOTES:

Depending on your air conditioner, some functions may not appear on the screen.

>Side menu>Timers menu

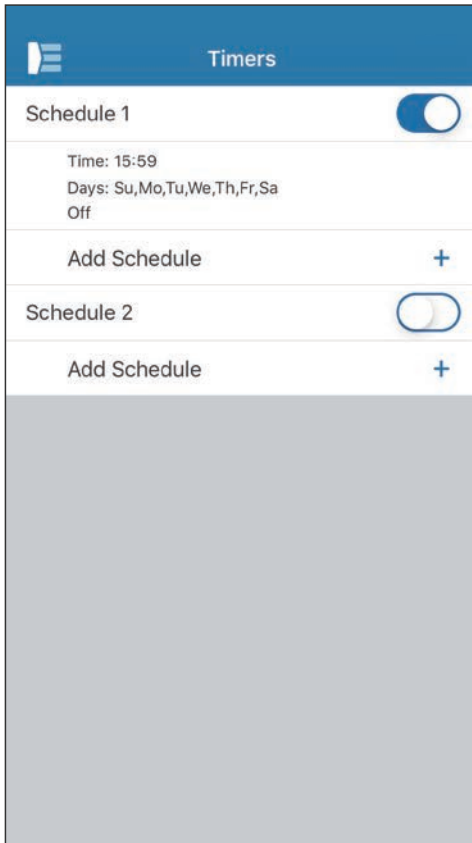

You can set the timer details (time, day, operation mode) on this screen.

Tap [Add Schedule] to add detailed schedules. (Refer to Schedule menu on next page.)

You can select either Schedule 1 or Schedule 2.

>Side menu>Timers >Schedule menu

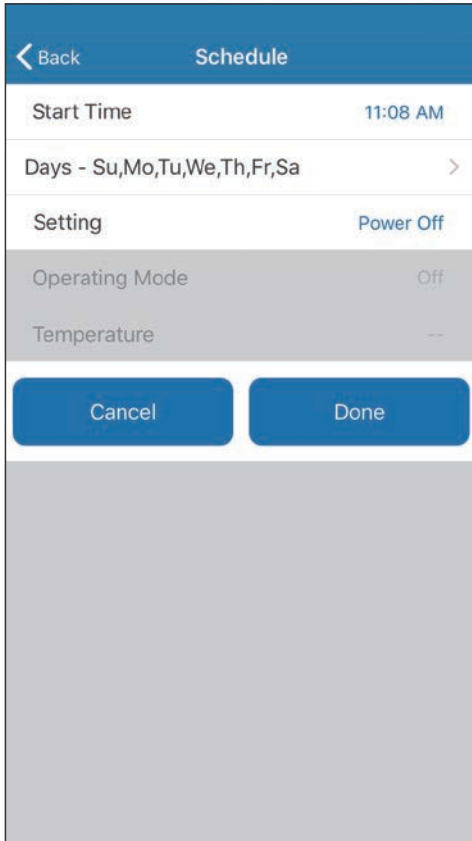

Set the schedule for various controls on this screen.

Tap [Days >] to set the weekly timer. (Refer to Days menu on the next page.)

After you have set the schedule, tap [Done] to save the settings.

>Side menu >Timers >Schedule >Days menu

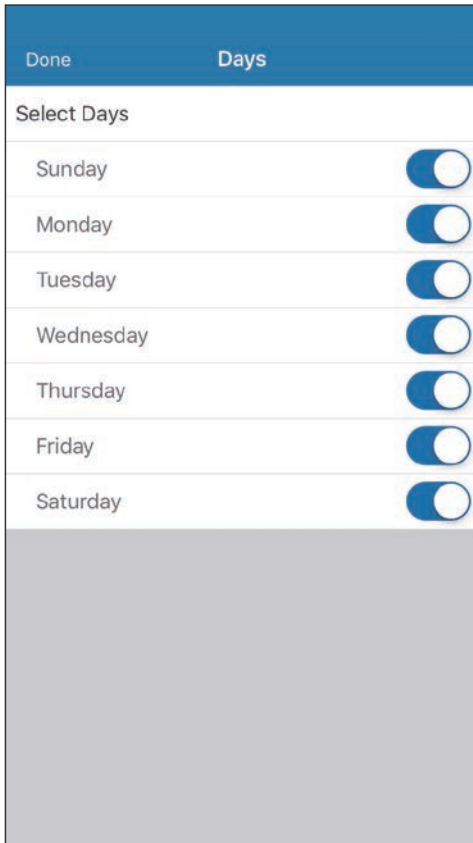

You can set the weekly timer on this screen.

Select and turn On or Off the air conditioner for each day from Sunday to Saturday.

>Side menu >Settings menu

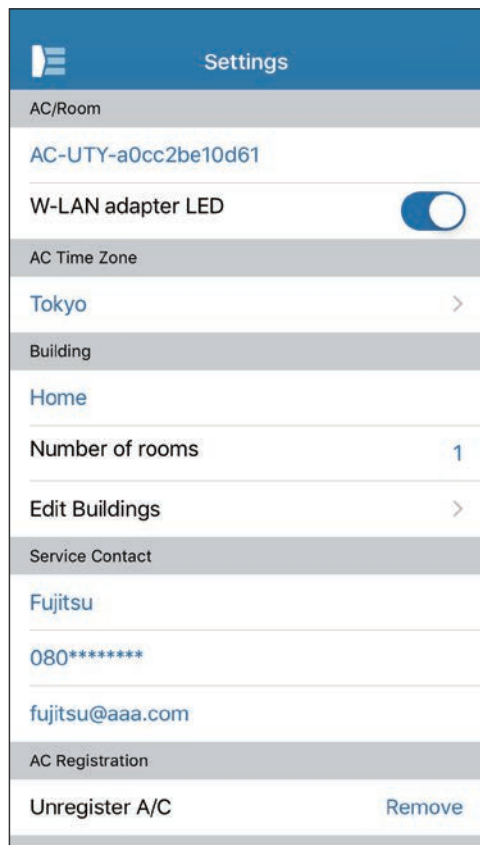

AC/Room:

You can edit details of individual A/Cs on this screen.

- A/C name:
Edit name using up to 20 characters. (e.g. Room name)
* The initial name will be the SSID of the W-LAN adapter.
- W-LAN adapter LED: You can turn on or off the LED of the W-LAN adapter.

AC Time Zone:

You can select the time zone of the region where the A/C is installed.

- * The timer set from the mobile app operates according to this time zone.

Building Settings:

You can consolidate multiple A/Cs as a building. Edit the building settings here.

- Select building
- Edit building name
- Delete building

(continue to next page)

>Side menu >Settings menu (continued)

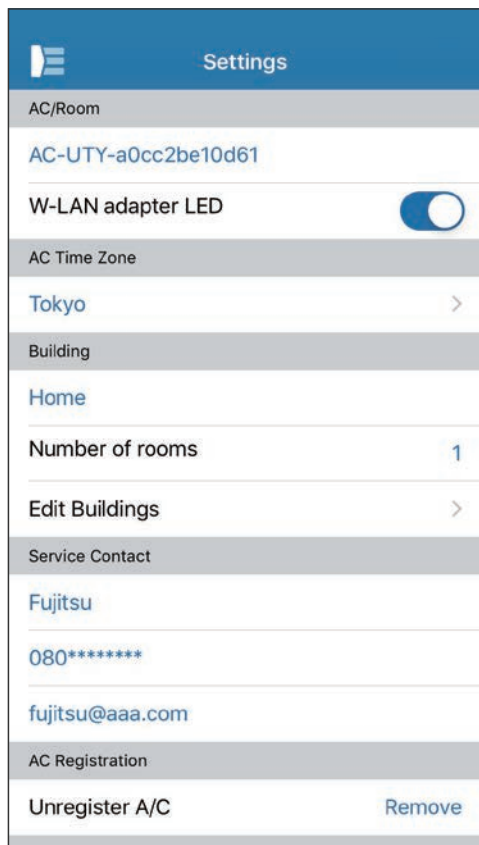

Service Contact:

Update information for future use. (Contact name, phone number, and Email address.)

Unregister A/C:

When disposing the W-LAN adapter or transferring it to a third party, be sure to unregister the A/C from your mobile app.

* You can also unregister the A/C from the Directory screen by pressing down on the A/C name.

NOTES:

After the A/C is unregistered, initialize the W-LAN adapter. If the SSID starts with "AC-UTY-", refer to the setting manual. If the SSID starts with "AP-", refer to the operating manual of the air conditioner.

>Side menu >App Settings menu

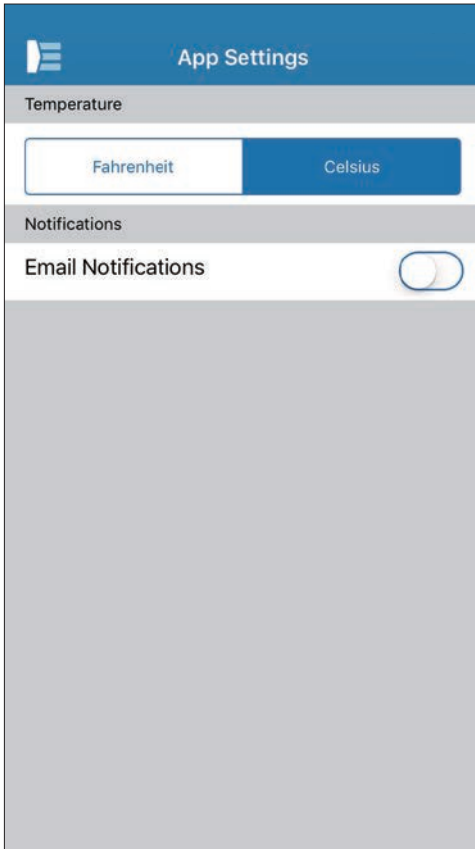

You can choose the temperature display between Fahrenheit or Celsius.

Notifications:

Turn to On if you desire notifications by email.

* Notifications will be sent when errors occur.

>Side menu >Account menu

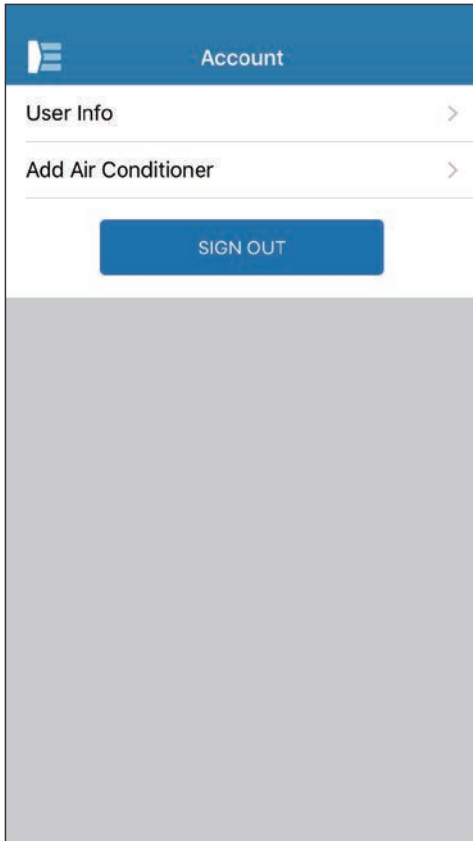

Update your account information by tapping [User Info].

You can also add a new air conditioner (A/C) from this page.

Tap [SIGN OUT] to sign out from this mobile app.

>Side menu >Account >User Info menu

Basic Information

First Name

Last Name

Email Address

Australia

1

Telephone

Update

Password

Current Password

New Password

Confirm New Password

Change

Delete account

Change the user information and password here.

Delete account: When you will no longer be using the W-LAN adapter, be sure to delete your account from the mobile app to protect your personal information.

NOTES:

Uninstalling the mobile app will not delete your personal information from the mobile app server. Please delete your account by tapping [Delete account].

Menu>Help

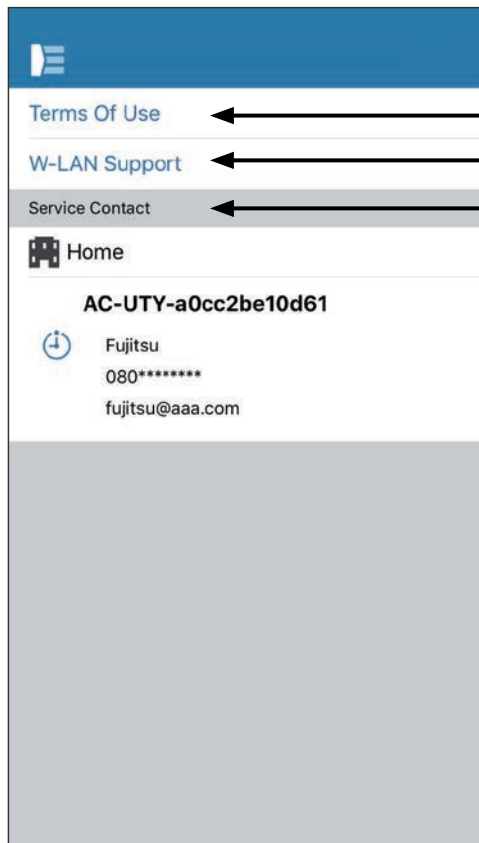

By tapping here, you can confirm the Terms and Conditions.

By tapping here, you can access the manuals on our website.

You can check the service contact information.

On/Off operation

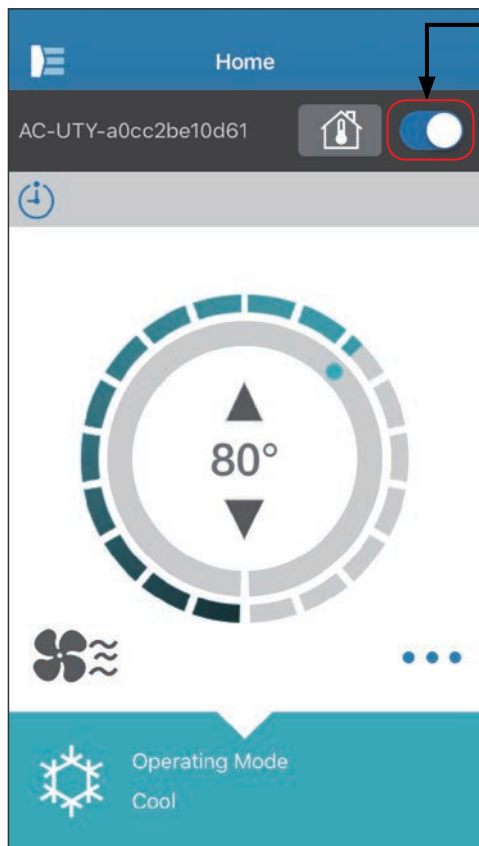

Selected A/C (On/Off)

Display the Individual A/C screen. Turn the air conditioner on/off by tapping the On/Off button.

If the air conditioner is off, the following screen will appear.

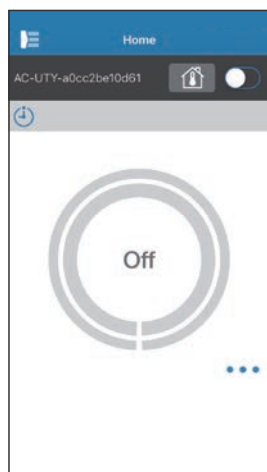

NOTES:

If you cannot turn the air conditioner on, please check the following;

- The air conditioner is connected to the power supply. (Via breaker or plug.)
- The W-LAN indicator (LED lamp) is ON, and working.
- Your wireless router is ON and connected to the Internet.

When the power is turned on from this mobile app, there will be no beeping sound from the air conditioner.

Operating mode selector

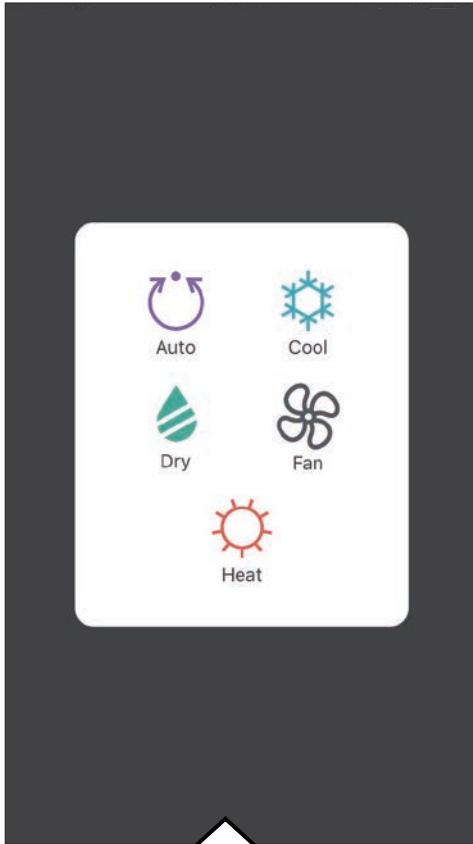

You can change the operating mode by tapping the icons.

Auto

Cool

Dry

Fan

Heat

NOTES:

Depending on your air conditioner, some functions may not appear on the screen.

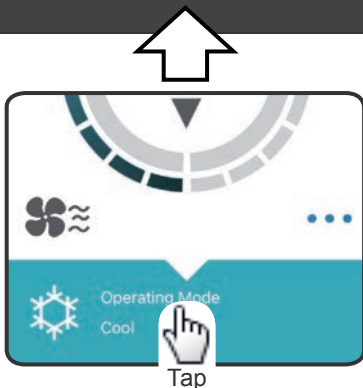

Other functions

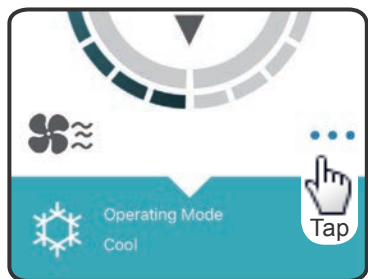
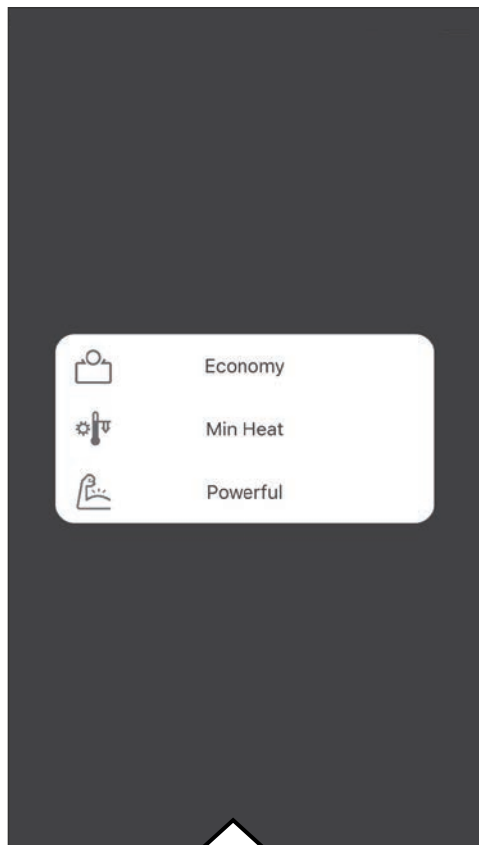

To activate the functions shown, tap the icon on the screen.

Example of functions:

Economy

Minimum Heat (10°C Heat)

Powerful

NOTES:

Depending on your air conditioner, some functions may not appear on the screen.

Example of screen when the Minimum Heat (10°C Heat) is activated.

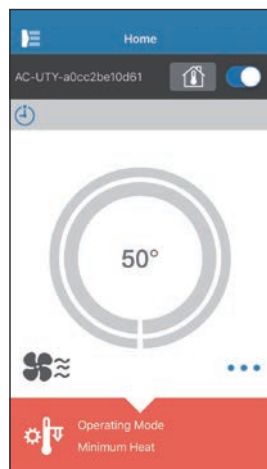

Fan Control

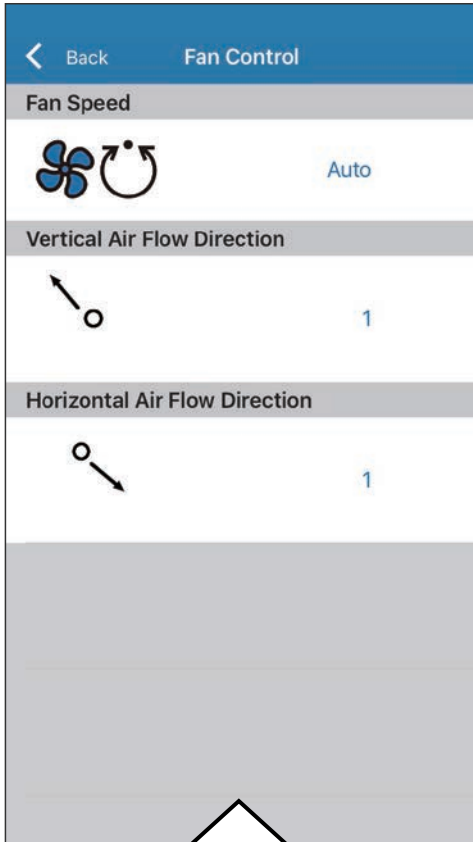

By selecting each item as shown on the screen, you can set the fan speed and airflow direction. For detailed information on each setting, refer to the operating manual of the air conditioner.

NOTES:

Depending on your air conditioner, some functions may not appear on the screen.

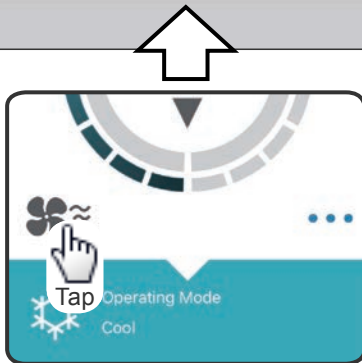

Temperature setting

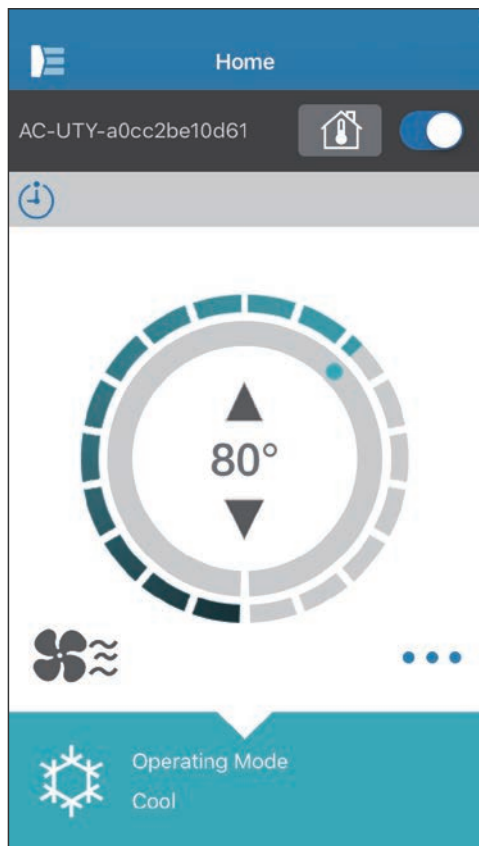











By tapping ▲▼ icons or by tracing the outer rim (circle) of the current temperature, you can set the temperature of your choice.

Settings can be changed for Auto, Cool, Heat, or Dry modes. The temperature range is different depending on the indoor unit.

NOTES:

- You will not be able to set below or above the temperature range.
- When operated at Fan mode, the temperature will not be shown.

Icon	Description	Status
	Error Message ^{*1)}	An error has occurred with the air conditioner. Please contact our authorized service personnel. *The error display may not appear when the air conditioner is not operating.
	Timers	The timer is activated.
	Prohibited	Operation from the mobile app is prohibited by the Central Controller.
	Defrost	At Heating operation, the outdoor unit performs Defrost operation. The indoor unit fan is stopped during this time.
	Oil Recovery	The outdoor unit is performing Oil Recovery operation. The indoor unit fan may be stopped during this time.
	Pump Down or Check Startup or Maintenance	The indoor unit is being inspected. The indoor unit operation is stopped at this time.
	Mode Mismatch	A mode which cannot be used simultaneously with a primary or other indoor units in operation is set in the same system. In this case, reset to a mode that can be operated simultaneously such as the Fan mode.
	Demand Control	The air conditioner is in Demand Control mode. For details, refer to the instruction manual for Demand Control.
	Filter Sign ^{*2)}	It is time to clean the filter. To erase the icon, tap the icon then select [Clear].
	Defrost or Oil recovery or Mode mismatch	The air conditioner status is at Defrost or Oil recovery or Mode mismatch. Please refer to the above for details of each item.

*1) Error Message



When errors occur, an Error Message icon () will appear on Directory screen and Home screen.

Tap the icon on Home screen to check the details of the error.



(Example)

*2) Filter Sign

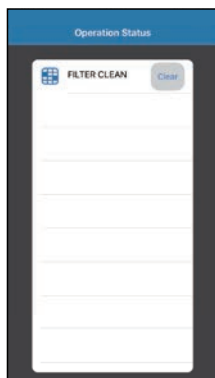

When the time to clean the filter, a Filter sign icon () will appear on Home screen.

- 1** Clean the air filter of the A/C. (Refer to the operating manual of the A/C.)
- 2** Tap Filter sign icon on the mobile app.
- 3** Select [Clear].

Check the following items before requesting repairs to this product.

Parts/Elements	Situation	Solutions
Operations from the mobile app	I am not able to operate this product from the mobile app.	Check that the power to the indoor unit is on.
		Check that the power to the wireless router is on.
		Check that your smartphone is not in flight mode.
		Check that you are not in a place where it is difficult to make a connection with radio waves.
		**Check that the W-LAN adapter is not in Sleep mode. Refer to "IMPORTANT TIPS" for details.
	The airflow direction on the mobile app is different from the actual position of the air conditioner.	The airflow direction may have been changed from a different source (remote controller or other mobile apps). Please redo the setting.
	The weekly timer does not work.	The weekly timer setting may not be on. Change the weekly timer setting from Off to On again.
		If you have unregistered the A/C from the mobile app, the weekly timer settings will be erased. To use the weekly timer, register the A/C from the mobile app and set the weekly timer again.
The weekly timer does not operate at the set time.	The weekly timer operates based on the AC Time Zone setting. Set the time zone the region where the A/C is installed.	
The temperature is not displayed on the mobile app.	Check that the thermo sensor of the wired remote controller is active and the set temperature is within the settable range.	
The Auto off function of the human sensor is not settable.	The Auto off function cannot be set from the mobile app. Use the wired or wireless remote controller.	



**Only for products with Sleep mode. Refer to the setting manual to see if it applies to your W-LAN adapter.

Please also refer to the operating manual of the indoor unit for troubleshooting related to the indoor unit.

■ State of the Wireless LAN indicators

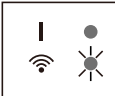

For W-LAN adapter with SSID which start with “AC-UTY-”.

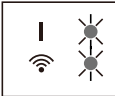
*Lighting pattern: ○ Off ● On  Flashing

State of the Lamps		Causes and Solutions
All the lamps are off		<p>The power to the W-LAN adapter is not on. →Check that the power to the air conditioner is on and that the air conditioner breaker is not tripped.</p> <p>**The W-LAN adapter may be in Sleep mode. →Push the Setting button on the W-LAN adapter, then check if the LED lights.</p> <p>The LED lamps are turned off by setting from the mobile app. →Refer to the Settings menu in the Side menu to turn the LED on.</p>
LED 2 is off or flashing fast (Repeating 0.5 seconds on / 0.5 seconds off)		<p>The power to the wireless router is not on. →Check that the power to the wireless router is on.</p> <p>There is a possibility that the W-LAN adapter is not properly connected to the wireless router. →Refer to the online manual to connect the wireless router.</p>
LED 1 is flashing fast (Repeating 0.5 seconds on / 0.5 seconds off)		<p>It is not possible to communicate with the air conditioner. →There may be an error in the air conditioner. Please contact authorized service personnel.</p>
All the lamps are flashing fast (Repeating 0.5 seconds on / 0.5 seconds off)		<p>There is a problem with the W-LAN adapter. →Disconnect the power supply to the air conditioner (via breaker or plug), and then re-connect. Refer to the online manual to setup the wireless LAN again.</p>

**Only for products with Sleep mode. Refer to the setting manual to see if it applies to your W-LAN adapter.

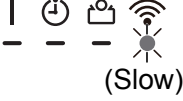
For W-LAN adapter with SSID which start with “AP-”.

State of the Lamps	Causes and Solutions
 <p>(Slow)</p>	<p>The power to the wireless router is not on. ⇒ Check that the power to the wireless router is on.</p> <p>There is a possibility that the W-LAN adapter is not properly connected to the wireless router. ⇒ Disconnect the power supply to the air conditioner (via breaker or plug), and then re-connect.</p>
	<p>The software of the W-LAN adapter is being updated.</p> <p>During the air conditioner registration (pairing of W-LAN adapter)</p>

■ Mobile app errors

Registration Errors (For Android)

Error messages	Causes	Solutions
Wi-Fi must be enabled to set up new device	The user has disabled Wi-Fi on their mobile device.	Enable Wi-Fi from the Android setting.
We weren't able to sign you onto null. Please go to the Wi-Fi settings and join the network from there. Return to the app when you're done.	The mobile device and air conditioner are connected to different Wi-Fi networks when attempting to register.	Connect the mobile device to the same network as the air conditioner, then retry the registration.
	Your region setting is incorrect.	Check the setting from the "Signing in" screen. Please set the correct region.
Could not connect to the device at this time. Please reset the device and try again.	The air conditioner is not connected to Wi-Fi.	Check if the router connected to the air conditioner has internet access. (You can check by connecting the mobile device to the router, then opening the website.) If there is no access, connect the router to the internet.
	Mobile device is not connected to the same network as the air conditioner.	Connect the mobile device to the same network as the air conditioner, then retry the registration.
The device failed to connect with service.	Your internet access may be down or a firewall may be blocking requests to the service.	Check if the router connected to the air conditioner has internet access. (You can check by connecting the mobile device to the router, then opening the website.) If there is no access, connect the router to the internet, then retry the registration.

Error messages	Causes	Solutions
<p>Could not register the device. Make sure the device is ready for registration.</p>	<p>The air conditioner is not connected to the router.</p>	<p>Enter the Wi-Fi setting on the mobile device, then check if the SSID of the air conditioner (“AC-UTY-*****”) or “AP-****-*****”) is connected. If the air conditioner is connected, retry the registration.</p>
	<p>The router the air conditioner is connected to, has no internet access.</p>	<p>Check if the router connected to the air conditioner has internet access. (You can check by connecting the mobile device to the router, then open the website.) If there is no access, connect the router to the internet, then retry the registration.</p>
	<p>The air conditioner is already registered.</p>	<p>If there is a mobile device that has already been registered to the air conditioner, unregister by using the registered mobile device. Retry the registration with the mobile device you wish to register.</p> <p>If you do not own the mobile device registered to the air conditioner (lost, property of previous owner, etc.), please ask your dealer or authorized service personnel to unregister the mobile device. Please notify the MAC address of the W-LAN adapter as written on the Wireless LAN label.</p>
	<p>*If the problem persists even if the all of the above is conducted, please contact your dealer or authorized service personnel. When asking for advice, please notify the MAC address of the W-LAN adapter as written on the Wireless LAN label.</p>	

Registration Errors (For iOS)

Error messages	Causes	Solutions
You need an internet connection to add new devices.	The user has disabled Wi-Fi on their mobile device.	Enable Wi-Fi from the iOS setting.
Could not register same LAN device. Make sure both devices are in the same LAN and try again to register.	The mobile device and air conditioner are connected to different Wi-Fi networks when attempting to register.	Connect the mobile device to the same network as the air conditioner, then retry the registration.
If you do not succeed even if you re-register several times, please initialize the air conditioner. Then press the 'Back to top' button to return to the top screen and start from the beginning.	Your region setting is incorrect.	Reconnect the air conditioner and the W-LAN adapter in the following procedure. <ol style="list-style-type: none"> 1. Initialize the W-LAN adapter. (Refer to the setting manual or the operating manual of the air conditioner.) 2. Set the region from "Signing in" screen. Select the region of the installation of the air conditioner. 3. Register the air conditioner (pairing of W-LAN adapter) again.

Error messages	Causes	Solutions
No registrable device was found. Make sure Wi-Fi setup was successful. This method only works if the Wi-Fi was recently performed.	The air conditioner is not connected to Wi-Fi.	Check if the router connected to the air conditioner has internet access. (You can check by connecting the mobile device to the router, then opening the website.) If there is no access, connect the router to the internet.
	Mobile device is not connected to the same network as the air conditioner.	Connect the mobile device to the same network as the air conditioner, then tap register button.
Could not register the device. Make sure the device is ready for registration.	The air conditioner is not connected to the router.	Enter the Wi-Fi setting on the mobile device, then check if the SSID of the air conditioner ("AC-UTY-*****" or "AP-*****") is connected. If the air conditioner is connected, retry the registration.

Error messages	Causes	Solutions
Could not register the device. Make sure the device is ready for registration.	The router the air conditioner is connected to, has no internet access.	Check if the router connected to the air conditioner has internet access. (You can check by connecting the mobile device to the router, then opening the website.) If there is no access, connect the router to the internet, then retry the registration.
	The air conditioner is already registered.	If there is a mobile device that has already been registered to the air conditioner, unregister by using the registered mobile device. Retry the registration with the mobile device you wish to register. If you do not own the mobile device registered to the air conditioner (lost, property of previous owner, etc.), please ask your dealer or authorized service personnel to unregister the mobile device. Please notify the MAC address of the W-LAN adapter as written on the Wireless LAN label.
	*If the problem persists even if the all of the above is conducted, please contact your dealer or authorized service personnel. When asking for advice, please notify the MAC address of the W-LAN adapter as written on the Wireless LAN label.	

General Errors (For Android)

Error messages	Causes	Solutions
No connectivity to Wi-Fi or the cloud. Please check your network connection.	The mobile device has no internet access.	Connect the mobile device to the internet.
An error occurred while trying to update your profile. Please try again later.		

Error messages	Causes	Solutions
Device is offline and cannot be modified.	The router the air conditioner is connected to, has no internet access.	Check if the router connected to the air conditioner has internet access. (You can check by connecting the mobile device to the router, then opening the website.) If there is no access, connect the router to the internet.
	The air conditioner is not connected to the router.	Check the W-LAN indicators. If they are flashing or off, please check the TROUBLESHOOTING "State of the Wireless LAN indicators".

General Errors (For iOS)

Error messages	Causes	Solutions
Failed to change password.	The mobile device has no internet access.	Connect the mobile device to the internet.
Could not determine service reachability.		
Failed to update property.		
Could not retrieve schedules.		
The operation couldn't be completed. Operation timed out.		

Error messages	Causes	Solutions
“Device name” is offline. (Device name varies depending on the air conditioner)	The router the air conditioner is connected to has no internet access.	Check if the router connected to the air conditioner has internet access. (You can check by connecting the mobile device to the router, then opening the website to check access.) If there is no access, connect the router to the internet.
	The air conditioner is not connected to the router.	Check the W-LAN indicators. If they are flashing or off, please check the TROUBLESHOOTING “State of the Wireless LAN indicators”.

Sign-in Errors (For Android/iOS)

Error messages	Causes	Solutions
Could not reach service.	The mobile device has no internet access.	Connect the mobile device to the internet.

>Side menu>Installer>Error History

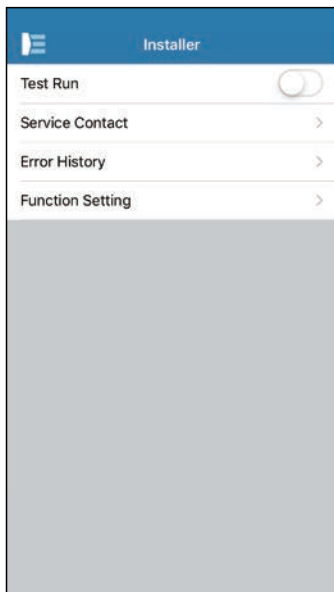

You can check the error history of the A/C.

- 1** Open the Side menu of the mobile app and then tap [Installer].
- 2** Enter the passcode "5679".
- 3** Tap [Error History].

The latest 10 errors will be displayed on the screen.

NOTES:

Do not operate [Test Run] and [Function Setting] on Installer screen under the normal use. They are functions for service or maintenance. When the settings are changed, the A/C may not operate properly.

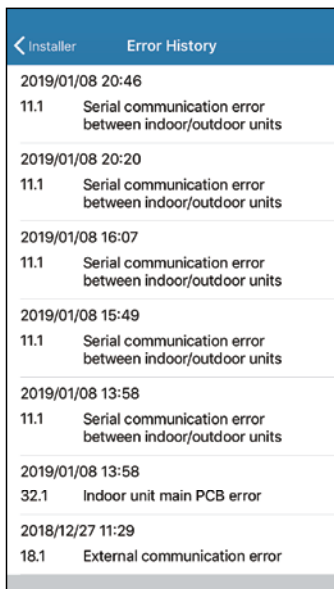

(For example)