

# ELECTRIC OVEN

USE AND INSTRUCTION MANUAL

MODD. EF 411 UD/000/00113 – EF 464 UD/000/00113

rev. 0

X:\Sgq\PRODOTTIFam. 1 - FORNIFORNO ELETTRICO\LTerz\MANUALI D'USO - Forno Elettrico 40 60 90 -  
LTerz\Eurofred - Forno Elettrico 40 60 90 - LTerz\EF\EF 411,464 UD\_000\_00113\Instruction manual EF 411  
UD\_000\_00113 - EF 464 UD\_000\_00113 -GB-rev. 0.doc

## Index

1. Technical service

---

2. General warnings

---

3. Technical specifications

---

4. Instructions for the installer

---

5. Use instructions (for the user)

---

6. Residual risks (for the user)

---

7. How to use the control panel

---

8. Oven cooking

---

9. Cooking advice

---

10. Routine cleaning and maintenance

---

11. Technical assistance

---

12. Informations to the consumers

---

13. Wiring layouts

---

## 1. Technical service

A technical check-up once or twice a year helps prolong the life of the appliance and guarantees better operation. Make sure that assistance is carried out solely and exclusively by qualified personnel. For any spare parts orders or for any information about the appliance, always mention the serial number and model (data indicated on the "technical data" plate at the rear of the oven).

## 2. General warnings

Very important!: keep this instruction book together with the appliance for future consultation. These warnings were drafted for your safety and for that of others. Please read them carefully before installing or using the appliance:

- If, on receipt of the goods, the **packaging** is damaged, write the following on the delivery note: **"I REVERSE THE RIGHT TO CONTROL THE GOODS"**, specify the damage and get the driver to sign in acceptance; send a claim in writing to the seller within 4 calendar days from the date of receipt. No claim shall be accepted after such period.
- The warehouse inside temperature must not be lower than  $-9^{\circ}\text{C}$ ; otherwise, the thermostat (regulation and safety thermostat) control devices of the machine will be damaged. Failure to observe this prohibition invalidates any responsibility of the manufacturer of the machine.
- The appliance is intended for professional use and must be utilised by qualified personnel trained to use it.
- Any modification which may be necessary on the electrical system to enable installation of the appliance, must be carried out solely by competent personnel.
- It is dangerous to modify or attempt to modify the characteristics of this appliance.
- Never clean the appliance with direct water jets, because, if any water enters, it could limit the machine's safety .
- Before doing any maintenance or cleaning jobs, disconnect the appliance from the electrical mains and allow it to cool.
- When the tilting door is wide open, do not put anything on the surface, because the door hinges could be irreparably damaged.
- Do not attempt to carry out the periodic controls or any repairs by yourself. Contact the nearest Service Centre and use only original spare parts.

**N.B.:** Improper or incorrect use and failure to observe the installation instructions shall release the manufacture from all responsibility. In this connection, the directives in the "POSITIONING" paragraph must be strictly observed.

## 3. Technical specifications

Dimensions of appliance LxDxH (mm)	790x665x635
Weight (Kg)	56
Convection heating element (kW)	3
Grill heating-element (kW)	/
Max. absorbed power (kW)	6,4
Power supply voltage (V)	400 2N (50/60Hz) - 230 V (50/60Hz)
Power cable diameter	4x2,5 mm <sup>2</sup> - 3x4 mm <sup>2</sup>
Type of cable	H07RN-F
Connecting electric cable	Tipo Y
Class	I
Degree of protection against humidity	IPX3
Water pressure (kPa)	100-200

The noise level of the appliance in operation is below 70 dB (A).

The "technical data" plate is positioned on the rear panel of the appliance.

## **4. Instructions for the installer**

The following instructions are aimed at the qualified installer, to ensure that he carries out the installation, adjustment and maintenance operations as correctly as possible and according to current legal regulations. Any operation must be performed with electrical power cut to the appliance. Before using the appliance, carefully remove the special adhesive film protecting the parts in stainless steel. Do not leave any glue residues on the surfaces. If necessary, remove them at once, with an appropriate solvent.

**Fitting the feet** - The feet are inside the appliance and must be secured on the four threaded holes on the base. If necessary, the height of the feet can be adjusted by screwing or unscrewing.

**Positioning** - Position the appliance perfectly horizontally on a table or similar support (the table or support must be at least 85 cm above the floor). Position it at a distance of not less than 10 cm from the side and rear walls, to enable natural ventilating air to circulate freely around it. The appliance is ventilated through specific openings on the metal walls of the outer housing, and ensures efficiency and long-life. For this reason it is strictly forbidden to obstruct these ventilation openings, even partially or for short periods. **Failure to observe this specific prohibition releases the manufacturer of the appliance from all responsibility and immediately voids any guarantee rights for the said appliance**, because its constructive conformity has been voluntarily compromised. Furthermore, the appliance is not suitable for embedding and for grouped positioning with other identical appliances.

**Electrical connection** - The appliance must be connected to the electrical mains according to current legal regulations. Before making the connection, make sure of the following:

- the voltage and frequency values of the power supply system match the values on the "technical data" plate affixed on the appliance;
- the limiting valve and the system are able to support the appliance's load (see the "technical data" plate);
- **the power supply system has an adequate earth connection according to current legal regulations;**
- a omnipolar switch with minimum between-contacts aperture of 3 mm, sized to the load and conforming to current legal regulations, is fitted between the appliance and the mains in the direct connection to the mains;
- the omnipolar switch used for connection is easy to reach when the appliance is installed;
- **the yellow/green earth wire is not interrupted by the switch;**
- the power supply, when the appliance is operating, must not deviate from the rated voltage value by  $\pm 10\%$ ;
- make sure that after inserting the power supply cord into the terminal block it does not come into contact with any of the cooking range's hot parts.
- **if the supply cable is damaged then it must be replaced by the manufacturer or by your technical support or by a qualified person to avoid any risk.**

**Connection to the water mains** - The appliance must be fed with softened drinking water, with hardness from 0.5°F to 5°F (it is obligatory to use a softener to reduce the formation of lime inside the cooking chamber) and pressure in the range from 100 to 200 kPa (1.0 - 2.0 bar).

Connection to the water mains should be made through the threaded 3/4" solenoid-valve on the rear (on the bottom) of the appliance, fitting in between a mechanical filter and an on/off tap (before you connect the filter, allow a certain quantity of water to flow out in order to drain any waste from the pipe).

### **Water drainage**

A drain pipe (see Fig. 1) comes out from the rear of the appliance, to drain the oven cavity. This pipe must be connected up to a pipe made to resist steam temperatures (90°C-100°C) with an

internal diameter of 30 mm (DN 30). To prevent choking, it is best to use a rigid pipe and make sure there are no "elbow" bends anywhere along the drain line.

Furthermore, the drain line must slope down (minimum slope 5%) along its full length (the length in question is from the appliance's drain pipe to the drain point and must not exceed 2 metres). The drain line must run into an open floor drain (Fig.2). In addition, there must be a free air gap of at least 25 mm (distance between the drain line coming from the appliance and the funnel on the drain standpipe). Whatever the case, in order to comply with current hygiene standards, the line connected to the appliance's drain pipe must not come into direct contact with the drain point. It is advisable to include a suitable trap in the line connecting the appliance's drain outlet to the grey water waste system, thus stopping the steam coming back out of the drain.

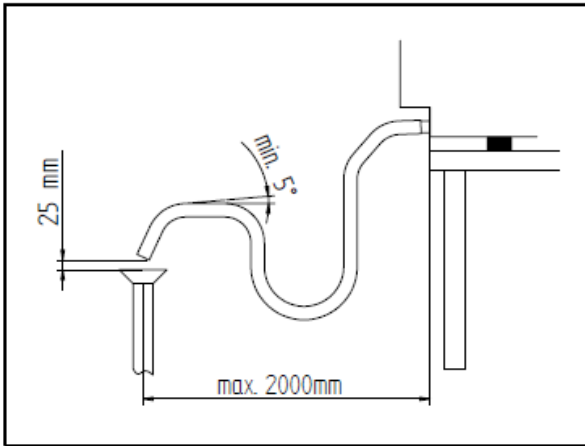

FIG. 1

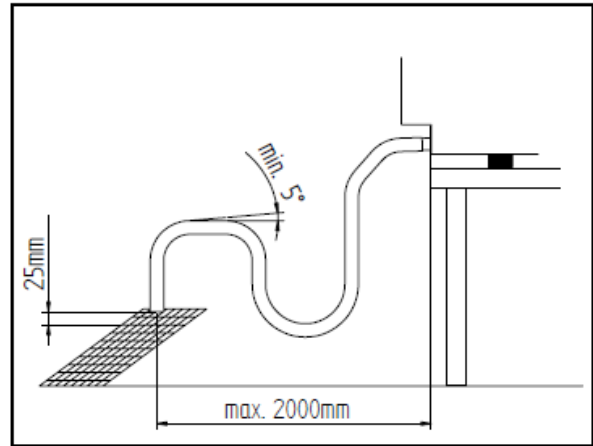
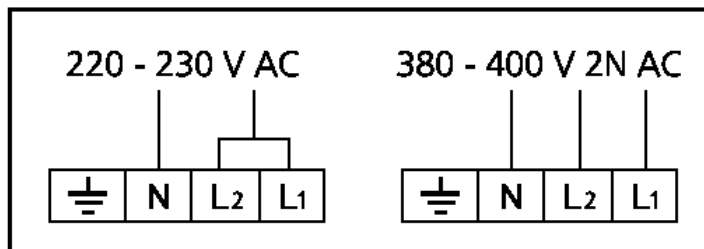

FIG. 2

**Connecting the power cable** - To access the terminal board, just remove the appliance's rear side-panel. Loosen the cable gripper and allow the cable to pass through it. Arrange the conductors so that the earth conductor is the last to detach from its terminal if the cable goes into a state of faulty traction. Connect the **phase** conductors to the terminals marked "L1" and "L2", connecting the **neutral** conductor to the terminal marked "N" and the **earth** conductor to the terminal marked with the symbol  $\perp$  according to the following lay-out:



(this electrical connection lay-out is located near the power supply terminal board ). Tighten the cable gripper and re-fit the rear side-panel of the appliance.

The appliance must be connected to an **equipotential system** whose efficiency must first be checked according to current legal regulations.

This connection must be made between different appliances by using the appropriate terminal marked with the symbol  $\perp$ . The equipotential conductor must have a minimum diameter of 2,5 mm<sup>2</sup>. The equipotential terminal is at the rear of the appliance.

**Safety thermal breaker** - The appliance has a manually reset safety thermal breaker. It protects against excessive dangerous over-temperatures which could be accidentally generated inside the appliance. This device is located on the back of the oven.

**5. Use instructions (for the user)**

For first use, we advise you to let the appliance to run load-free at maximum temperature for about one hour. In this way, any unpleasant smells due to thermal insulation and residual work grease are eliminated. This appliance must be used solely for the purpose for which it was expressly designed, i.e. cooking foods in the oven. Any other use is considered unsuitable.

The appliance can be used: for all oven cooking of deserts, pizzas, meat, fish, vegetables, as well as for gratinating, and for re-conditioning cooled and frozen foods. When placing food in the cooking compartment, leave a space of at least 40 mm between pans in order not to over-obstruct air circulation. Do not use pans with higher than necessary edges: edges are barriers which prevent the circulation of hot air. Warm up the oven before every cooking operation to obtain maximum uniformity. Do not salt foods in the cooking compartment.

**6. Residual risks (for the user)**

After a cooking operation, open the door cautiously, to avoid a violent outflow of heat which could cause burns. While the oven is in operation, pay attention to the hot zones (marked on the appliance) of its external surfaces. Place the machine on a bench or similar support, at a height of at least 85 cm from the floor. The bench or support must be able to support the weight of the machine and house it correctly. The appliance contains electrical parts and must never be washed with a jet of water or steam. The appliance is electrically connected: before attempting any cleaning operation, cut power to the appliance. To prevent incorrect connection of the appliance, the relevant electrical and water connections are marked by identification plates.

Do not use the door handle to move the appliance (the glass panel may break). When the tilting door is wide open, do not use the internal surface to place objects to avoid damaging permanently the door hinges.

**7. How to use the control panel**

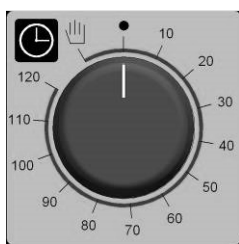
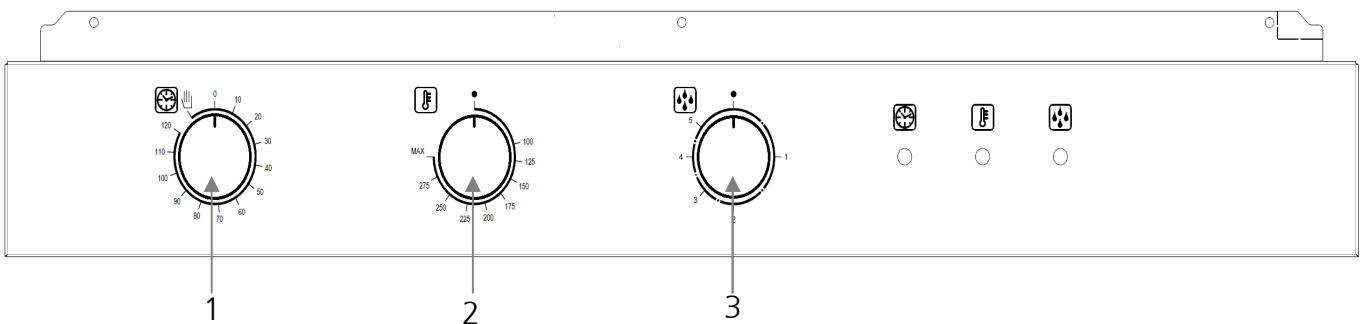

Fig. 3



Fig. 4

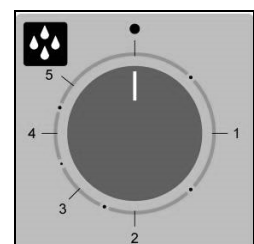



Fig. 5

**Programming cooking time** - To run the oven, turn the programmer knob (Fig. 3) in line with symbol  (continuous operation) or in line with the selected cooking time (up to 120 minutes). In the second case, end of cooking is signalled by the oven switching OFF automatically.

**Programming cooking temperature** - Turn the knob of the adjustment thermostat (Fig. 4) in line with the temperature selected for cooking.

**Programming vapour quantity** - To generate vapour while the oven is in operation (cooking compartment hot), turn the knob of the automatic humidifier (Fig. 5) in line with the required value (from 1 to 5). If you turn the knob to position • (OFF) the humidifier will stop operating.

**Control thermostat indicator light** - The control thermostat orange indicator light goes OFF whenever the programmed temperature is reached inside the cooking compartment. It lights up again when the thermostat is tripped to re-establish this temperature.

**"End of cooking" programmer indicator light** - The programmer green indicator light indicate that the oven is operating and that cooking time is active.

**Oven internal light** - The light is always on when the oven is operating.

**To switch off the oven** - Turn OFF the knobs of the "end of cooking" programmer and of the thermostat. When you have finished using the oven, shut off the water ON/OFF tap upstream of the appliance and cut out electric power.

## **8. Oven cooking**

For cooking, before putting food in, warm up the oven to the required temperature. When the oven reaches the temperature, put the food in and check cooking time. Switch off the oven 5 minutes before the theoretical time in order to recover stored heat.

**Convection cooking** - Activate the oven and turn the thermostat knob in line with the required temperature.

**Convection cooking + steam (dry heat + wet heat)** - Operate the oven and turn the thermo state knob to the desired temperature and the humidifier knob the desired steam quantity.

**Defreezing** - Operate the oven and turn the thermo state knob and the humidifier knob in correspondence of position OFF (•).

## **9. Cooking advice**

**Convection cooking** - Heat is transferred to the foods by pre-heated air, forced to circulate by in the cooking chamber. The heat quickly and uniformly reaches all parts of the chamber, enabling simultaneous cooking of different types of food (providing they have the same cooking temperature), placed on the shelves without mixing tastes and smells. Convection cooking is particularly convenient for rapid defreezing, and for sterilising preserves and drying mushrooms and fruit.

**Cooking desserts** - Desserts require a very high temperature (usually from 150 to 200°C) and a pre-heated oven (about ten minutes). The oven door must not be opened until at least 3/4 of the cooking time has elapsed. Whipped dough must be difficult to detach from a spoon because excessive fluidity would prolong cooking time to no avail.

**Cooking meat** - Meat to be cooked should weight at least 1 Kg to prevent it drying too much. Very tender red meats to be cooked rare, which must be cooked on the outside to keep all their gravy, require short cooking time at high temperature (200-250°C). The gravy ingredients must be placed immediately in the pan only if the cooking temperature is brief, otherwise they should be added during the last half-hour. You can check the degree of cooking by squashing the meat



with a spoon: if the meat does not yield, it is correctly cooked. For roast beef and fillet, which must remain pink inside, cooking time must be very brief. Meats may be placed on a plate suitable for oven cooking or directly on the grill, under which you should place a tray to collect the gravy. When cooking has finished, we advise you to wait for 15 minutes before cutting the meat so that the gravy does not come out. Before being served, the dishes may be kept hot in the oven at minimum temperature.

## **10. Routine cleaning and maintenance**

**(WARNING: Cut power to the appliance before every operation)**

**General cleaning** - Clean the oven when it is cold. Wash enamelled parts with lukewarm water and soap, do not use abrasive products, steel wool, or acids, which could ruin them. To clean the steel parts, do not use products containing chlorine (sodium hypochlorite, hydrochloric acid, etc) even if diluted. Use specific off-the-shelf products or a little hot vinegar. Rinse thoroughly with water and dry with a soft cloth. Clean the glass door of the oven with hot water only, and do not use rough cloths. Do not allow foods (especially acid foods such as salt, vinegar, lemon, etc) to stagnate on the stainless steel parts, because they could deteriorate. Do not wash the appliance with direct jets of water, because if water enters, this could limit the appliance's safety. Do not use corrosive substances (e.g. hydrochloric acid) to clean the oven's support bench.

**Cleaning the oven** - It is good practice to clean the oven interior at the end of every day of duty. In this way it will be easier to remove cooking residues, preventing them from burning when the oven is next used. Clean it accurately with hot water and soap or with the appropriate off-the-shelf products.

### **Cleaning the oven door**

To clean the oven door thoroughly, proceed as follows:

- fully open the door;
- insert the equipped plugs in the "A" holes on the hinges (Fig. 6);
- lift the door gently and withdraw it (Fig. 7);
- put back the door in the initial position by operating inverserly.

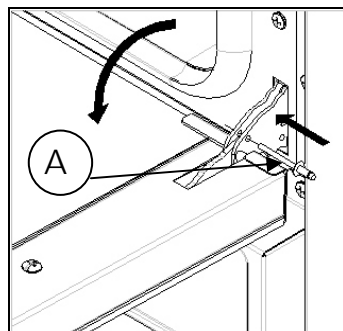

Fig. 6

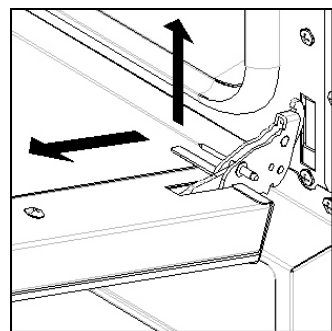

Fig. 7

**Replacing oven lamp** - Electrically switch off the appliance; unscrew the protective glass cap; remove the faulty halogen lamp and insert the new one by using paper or cloth to not touch the lamp with bare hands.

*Please note that the new halogen lamp must have the same characteristics as the one removed.* Put back the lamp cover with the gaskets and turn on the electricity.

## **11. Technical assistance**

Before leaving the factory, the appliance was completely regulated and tested by expert specialised personnel to guarantee the best operating results.

All repairs and settings must be performed with utmost care and attention, respecting national safety regulations in force. Always contact your retailer or our nearest Service Centre, giving details of the problem, the appliance model and the serial number (on the rating plate on the rear panel).

## **12. Informations to the consumers**

Further to Directive 2002/96/EC, the symbol of the crossed rubbish skip on the appliance means that at the end of its life, the product must be disposed of separately from the other rubbish. The user must hand the appliance to a specialised waste collection centre for electric and electronic equipment.



The separate collection of the rubbish and subsequent treatment, recovery and disposal help to produce other equipment using recycled materials, reducing the negative effects on the environment and public health, which would be caused by incorrect management of the rubbish.

Should the user dispose of the product abusively, administrative sanctions would be applied.

## 13. Wiring layouts

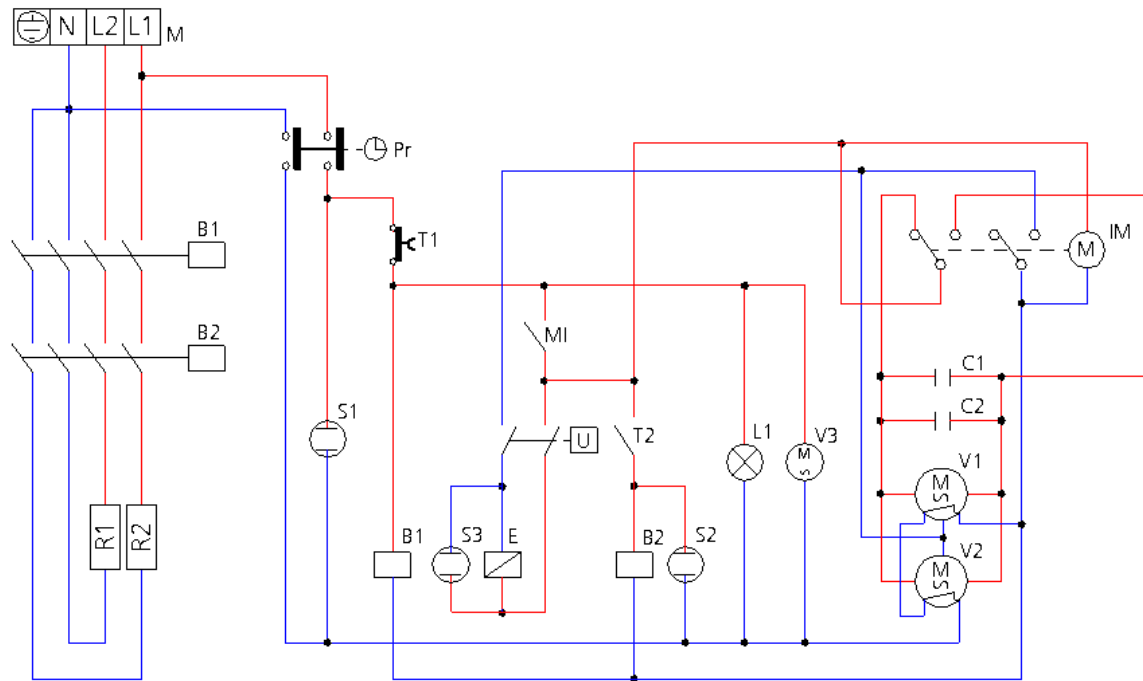

### Key

M	Power terminal board	V1-V2	Radial motoventilators
Pr	"End of cooking" programmer	V3	Tangential motorised ventilator
MI	Door microswitch	C1-C2	Capacitors
T1	Safety thermostat	IM	Operating direction reversing element
T2	Control thermostat	B1-B2	Contactors coil
R1-R2	Circular heating elements	S1	Programmer indicator light
E	Humidifier solenoid-valve	S2	Thermostat indicator light
U	Humidifier switch	S3	Humidity indicator light
L1	Lighting lamp		