

*INSTRUCTION MANUAL ON INSTALLATION,
USE AND MAINTENANCE OF PASTRY GAS
OVENS WITH MECHANICAL PANEL*



COD.: ZSL0736

REV. 00 / 2002

CONTENTS

1. INSTALLATION	Pag. 3
1.1 IMPORTANT NOTICES	Pag. 3
1.2 POSITIONING	Pag. 3
1.3 ADJUSTING THE DOOR	Pag. 4
1.4 CONNECTING TO WATER SUPPLY	Pag. 4
1.5 CONNECTING THE DISCHARGE PIPE	Pag. 4
1.6 WIRING	Pag. 4
1.7 CONNECTING UP GAS	Pag. 5
INSTALLATION INSTRUCTIONS	Pag. 5
CHECKS BEFORE INSTALLATION	Pag. 5
CHECKING HEAT OUTPUT	Pag. 6
CHECKING GAS PRESSURE	Pag. 6
REPLACING NOZZLES	Pag. 6
1.8 FUME EVACUATION	Pag. 7
CONNECTION TO FUME FLUE WITH NATURAL DRAUGHT	Pag. 7
INSTALLATION UNDERNEATH EXTRACTION HOOD	Pag. 7
2. INSTRUCTIONS ON USE	Pag. 8
2.1 COMMISSIONING	Pag. 9
DISPLAY	Pag. 9
2.2 SETTING	Pag. 9
SWITCHING ON	Pag. 9
TEMPERATURE	Pag. 9
TIME	Pag. 9
2.3 SUPPLEMENTARY FUNCTIONS	Pag. 10
HUMIDIFIER	Pag. 10
SPEED CHANGING	Pag. 10
CONDENSATE VALVE CONTROL	Pag. 10
2.4 SWITCHING OFF	Pag. 10
2.5 CLEANING	Pag. 10
3. MAINTENANCE	Pag. 11
CLEANING	Pag. 11
STEAM VENT	Pag. 11
3.1 SAFETY AND MONITORING COMPONENTS	Pag. 11
SOLENOID VALVE	Pag. 11
DOOR MICROSWITCH	Pag. 11
MOTOR THERMAL OVERLOAD PROTECTION	Pag. 11
SAFETY THERMOSTAT	Pag. 11
FLAME CONTROL	Pag. 11
4. WHAT TO DO IF	Pag. 12
THE OVEN DOES NOT START	Pag. 12
THE VALVE CONTROL SWITCH COMES ON	Pag. 12
THE FAN STOPS DURING OPERATION	Pag. 12
THE OVEN DOES NOT PRODUCE HUMIDITY	Pag. 12
THE INTERIOR LIGHT DOES NOT WORK	Pag. 12
4.1 CHECK MUST BE CARRIED OUT ONLY BY AN AUTHORISED TECHNICIAN	Pag. 13
ADJUSTING DOOR MICROSWITCH	Pag. 13
RESETTING SAFETY THERMOSTAT	Pag. 13
ADJUSTING SOLENOID VALVES	Pag. 13
WATER FILTER	Pag. 13
MOTOR OVERLOAD PROTECTION	Pag. 13
FLAME CONTROL	Pag. 14

1.

INSTALLATION

1.1 IMPORTANT NOTICES



Read this manual carefully because it provides important information on safe installation, use and maintenance of the appliance. Keep this manual carefully, so that it can be consulted by different users.

- The appliance must be installed in accordance with the manufacturer's instructions by professionally qualified personnel.
- The appliance must be used only by personnel who have been trained in its use.
- If the appliance is broken or faulty, disconnect it. If it needs to be repaired, use only an after-sales centre that has been approved by the manufacture and ensure that manufacturer approved spare parts are used.
- Failure to comply with these regulations may jeopardise appliance safety.

The appliance conforms to the following directives:

CEE 89/336: RADIO FRQUENCIES AND ELECTROMAGNETIC DISTURBANCES (E.M.C.)
CEE 73/23 – 93/68: LOW VOLTAGE
CEE 90/396: GAS DIRECTIVE

EN 60335.1-36: CONVECTION
EN 203.1 E 203.2: GAS-POWERED KITCHEN APLLIANCES - SAFETY REQUIREMENTS

1.2 POSITIONING

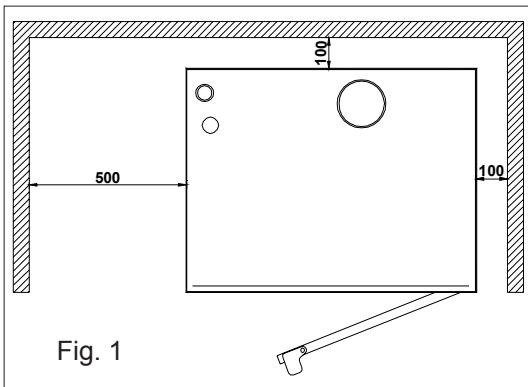
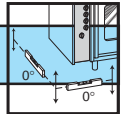
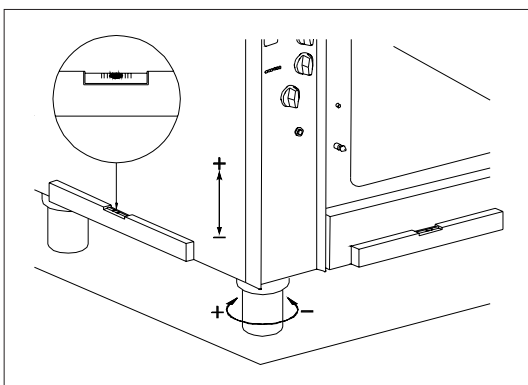

Fig. 1

Remove the appliance from its packing, check that it is undamaged and place it in position for use. Do not position it against walls, panelling, partitions, kitchen furniture or flammable wall coverings. Maintain a distance of **at least 10mm** from walls or other equipment on all sides, Leave at least 500 mm of space between the left-hand side and the wall (Fig. 1). Place the appliance in a well ventilated place.



Level it by adjusting the feet in the manner shown in Fig. 2.

Slowly remove the protective film from the outside panels, making sure that there are no traces of adhesive. Check that openings and gaps for taking in or venting heat are not obstructed.

1.3 ADJUSTING THE DOOR

Fig.3

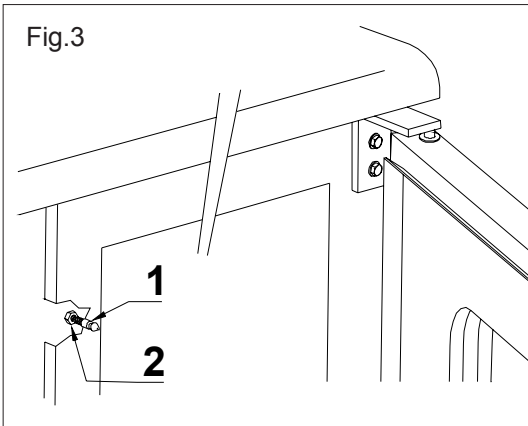

Check that the door closes properly on the oven chamber and forms a perfect seal.

If necessary, adjust the closing pin (1) by first loosening the internal counternut (2) behind the control panel.

1.4 CONNECTING TO WATER SUPPLY

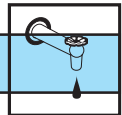

Max. water pressure: (250K/Pa) 2.5bar. Connect the water pipe to the cold water supply using the special mechanical filter supplied and a stopcock.

Before connecting to the filter, run through a little water to wash out any ferrous deposits from the pipe. .

1.5 CONNECTING THE DISCHARGE PIPE

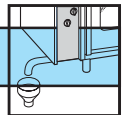
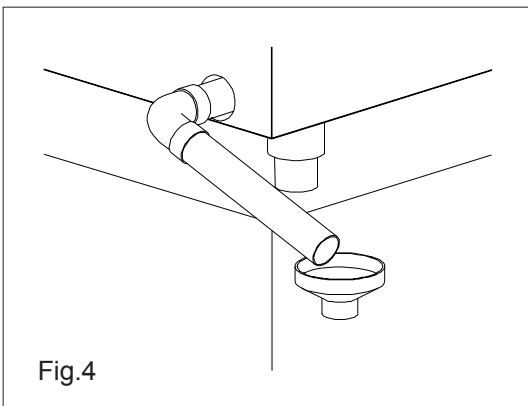
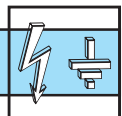

Fig.4



To connect the drain pipe, fit the funnel supplied at the appliance's outlet to ensure that the water will drain easily. The discharge pipe must always be free in order to prevent pressure building up inside the chamber (Fig. 4).

1.6 WIRING



Check that there is an efficient earth system that complies with wiring regulations.

To connect the power supply, fit a master switch of adequate capacity in an easily accessible position between the appliance and the main power supply. Its contacts must open by at least 3 mm.

Loosen the screws to remove the left-hand side of the appliance, insert the power cable into the cable clamp hole, connect the cable to the terminal clamp and fix it in position with the cable clamp.

Use a cable that is able to carry the load! Check out the table that is attached to the wiring diagram inside the dismantled side.

The terminal clamp has this identification:

L1 N \perp

for single-phase versions (**maintain polarity**)

L1 L2 L3 N \perp

for three-phase versions (**check fan rotation direction, see section 4**).

The operating voltage of the appliance must not deviate by more than 10% from nominal voltage.

The appliance must be electrically isolated and the efficiency of the isolation system must comply with current regulations. A clamp on the frame marked with the message 'isolation' must be used to connect the appliance to the isolation system.

Check that the safety thermostat circuit is closed (see chapter 4).



INSTALLATION INSTRUCTIONS

Only qualified persons must be entrusted with installation operations, adapting the appliance to different types of gas, commissioning and eliminating system faults. All current rules and regulations must be complied with. The gas fittings, wiring and the premises on which the appliance is installed must comply with current rules and regulations. In particular, for combustion, burners require 2m³/h per kW of installed power. Accident prevention and fire and anti-panic safety regulations must be enforced in places that are open to the public.

CHECKS BEFORE INSTALLATION

Look at the rating plate on the left side of the oven to check that the appliance has been tested and approved for the user's type of gas supply. Check that the nozzles on the appliance are suitable for the gas supply. Check the data on the rating plate to ensure that the pressure reducer is adequate for the appliance's gas supply (Fig. 5).

Fig. 5

			CAT/KAT	GAS/GAZ	G30	G31	G20	G25		
			II2H3+	P mbar	30	37	20		IT	
			II2E+3+	P mbar	28	37	20	25	FR	
			II2E+3+	P mbar	28	37	20	25	BE	
CE			II2H3B/P	P mbar	30	30	20		DK	
			II2H3+	P mbar	28	37	20		ES	
TIPO/TYPE		B11	II2H3+	P mbar	28	37	20		IE	
MOD.			II2L3B/P	P mbar	30	30		25	NL	
			II2H3+	P mbar	30	37	20		PT	
MAT.			II2H3+	P mbar	28	37	20		GB	
$\sum Q_n$ kW			II2 ELL3B/P	P mbar	50	50	20	20	DE	
			II2H3+	P mbar	28-30	37	20		GR	
G30-G31 Kg/h	G20 m ³ /h	G25 m ³ /h	II2H3B/P	P mbar	50	50	20		AT	CH
			II2H3B/P	P mbar	30	30	20		SE	
			II2H3B/P	P mbar	30	30	20		FI	
			I3B/P	P mbar	30	30			NO	
Vac kW Hz Made in Italy										

Unless the customer requests otherwise when placing his order, the appliance has been calibrated by the manufacturer to use Natural gas (G20) at 20mbar.

If gas supply pressure deviates by more than 10% from nominal pressure, fit a pressure regulator upstream of the appliance to ensure that nominal pressure is maintained.

Do not reduce the diameter of the pipe between the reducer and the appliance.

Fit a gas filter upstream of the pressure regulator in order to optimise operating efficiency.

CHECKING HEAT OUTPUT

The appliance is operating correctly if pressure keeps within these limits:

GAS TYPES		PRESSURE in mbar		
		NOM.	MIN	MAX
NATURAL GAS G20		20	18	25
L.P.G.	G30/31	28-30/37	25/25	35/45

If pressure is not within these limits, the working efficiency of the appliance will be impaired.

Connect the appliance to a special pipe for LPG with an internal section of at least 16 mm for G1/2" connections and of at least 20 mm for G3/4" connections. The pipe fitting must be in metal but the pipe can be fixed or flexible. Fit stopcocks or gate valves with an internal diameter that is not less than that of the pipe fitting. After connecting to the gas supply, check that there are no leaks from the joints and fittings. To check for leaks, use soapy water or a foamy product that has been specifically designed to detect leaks.

CHECKING GAS PRESSURE

Check that the nozzles fitted are suitable for the type and pressure of the gas supplied. If they need to be changed, see the paragraph below.

Once the appliance has been connected, check gas pressure.

Gas pressure must be adjusted directly on the control valve, following this procedure:

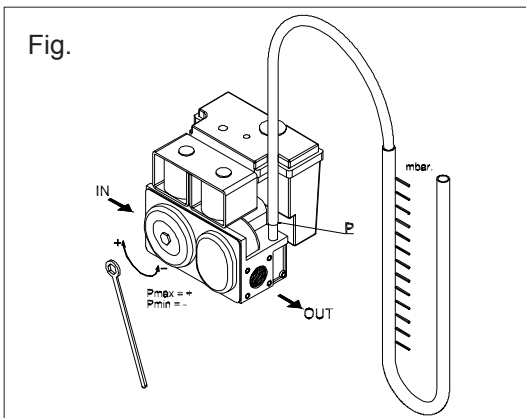

- Remove screw "P" (Fig.6) on the pressure connection inside the valve.
- Place the gauge on the pressure connection.
- Check that the nozzles are correct.
- Light the oven and start up the burners.
- Adjust gas pressure to the values shown on the table by adjusting the 8-mm screw. Remember that turning the screw clockwise increases pressure and turning it anticlockwise decreases it.
- When the correct pressure has been reached, switch off the oven, remove the gauge and fit the locking screw. Make sure that none of the liquid used to detect leaks has seeped out.

NOZZLE TABLE FOR GAS TYPES

Only use manufacturer-approved nozzles and do not tamper with them in any way!

OVEN	G30-30mbar.	G31-37mbar.	G20-20mbar.	G25-20mbar.	G25-25mbar.	G30/31-50mbar.
GF5	120	120	165R	185R	165R	105
GF7	150	150	220R	240R	220R	140
GF10	160	160	230R	250R	230R	150

REPLACING NOZZLES

To connect to a type of gas that is different from the one specified on the rating plate, the burner nozzles in the chamber and the nozzles of the steam generator must be replaced by following this procedure.

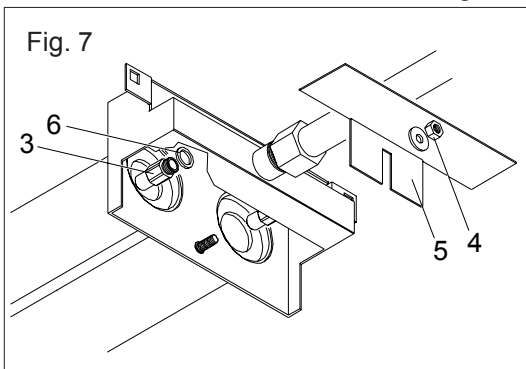

- Remove screw 4 (Fig7) and air regulator 5, if it exists.
- Unscrew nozzle 3 and replace it with a nozzle that is suitable for the type of gas that will be used.
- Refit washer 6.
- Reset air regulator 5, if it exists.
- Use the air regulator to adjust burner flame.
- Nozzles are marked in hundredths of a millimetre.
- After replacing the nozzles, check gas pressure.

1.8 FUME EVACUATION

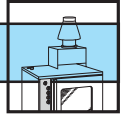

The appliances must be installed in compliance with installation regulations in premises with adequate fume evacuation systems.

The following types of connection exist:

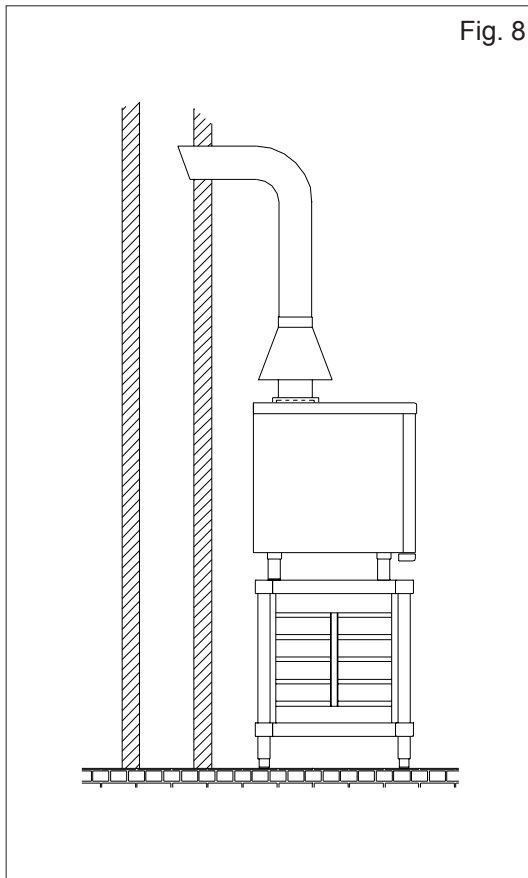

CONNECTION TO FUME FLUE WITH NATURAL DRAUGHT

To connect the appliances to a flue that expels the waste gas into the outside atmosphere, see the illustration.

The fumes are conveyed to the outside atmosphere or to a flue by means of a pipe that can withstand temperatures of up to 300°C and which has a diameter that is great as that of the top of the flue (Fig. 8).

WARNING: Check that fume evacuation is not hindered by obstructions and/or an excessively long evacuation pipe (maximum length: 3m).

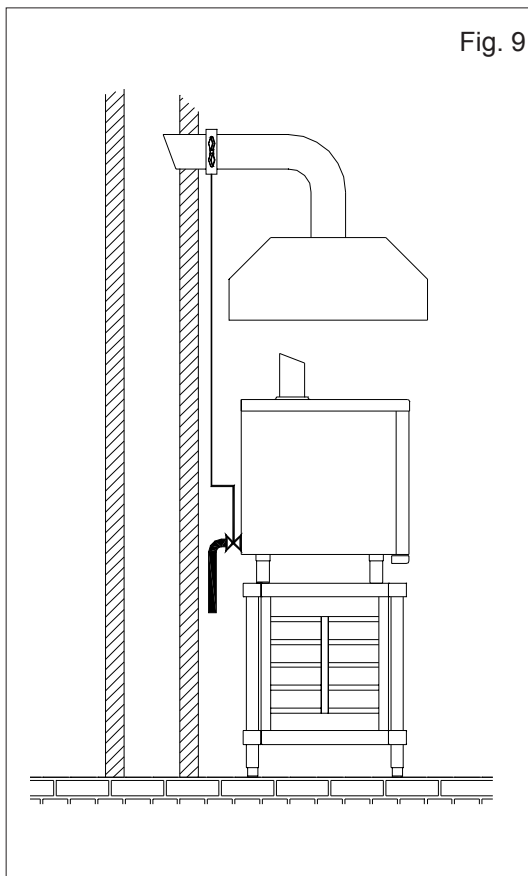

INSTALLATION UNDERNEATH EXTRACTION HOOD

If the appliance is installed underneath an extraction hood, comply with the following instructions:

The volume extracted must be greater than the volume of burnt gas generated (see current regulations).

The gas supply to the appliance must be controlled directly by the supply system and must be cut off immediately pressure falls below the prescribed values.

It must be possible to reconnect the gas supply to the appliance only manually.

The appliance is supplied with the flue connection. This must be fitted after the oven has been positioned underneath the extraction hood. Check the material from which the hood filter is made because the temperature of the burnt gas leaving the oven could reach 300°C.

The end of the appliance's evacuation pipe must be placed inside the hood's base perimeter (Fig. 9).

2.

INSTRUCTIONS ON USE

The appliance must be used only for its designed purpose. Any other use is improper.
Do not leave the oven unattended whilst it is running.

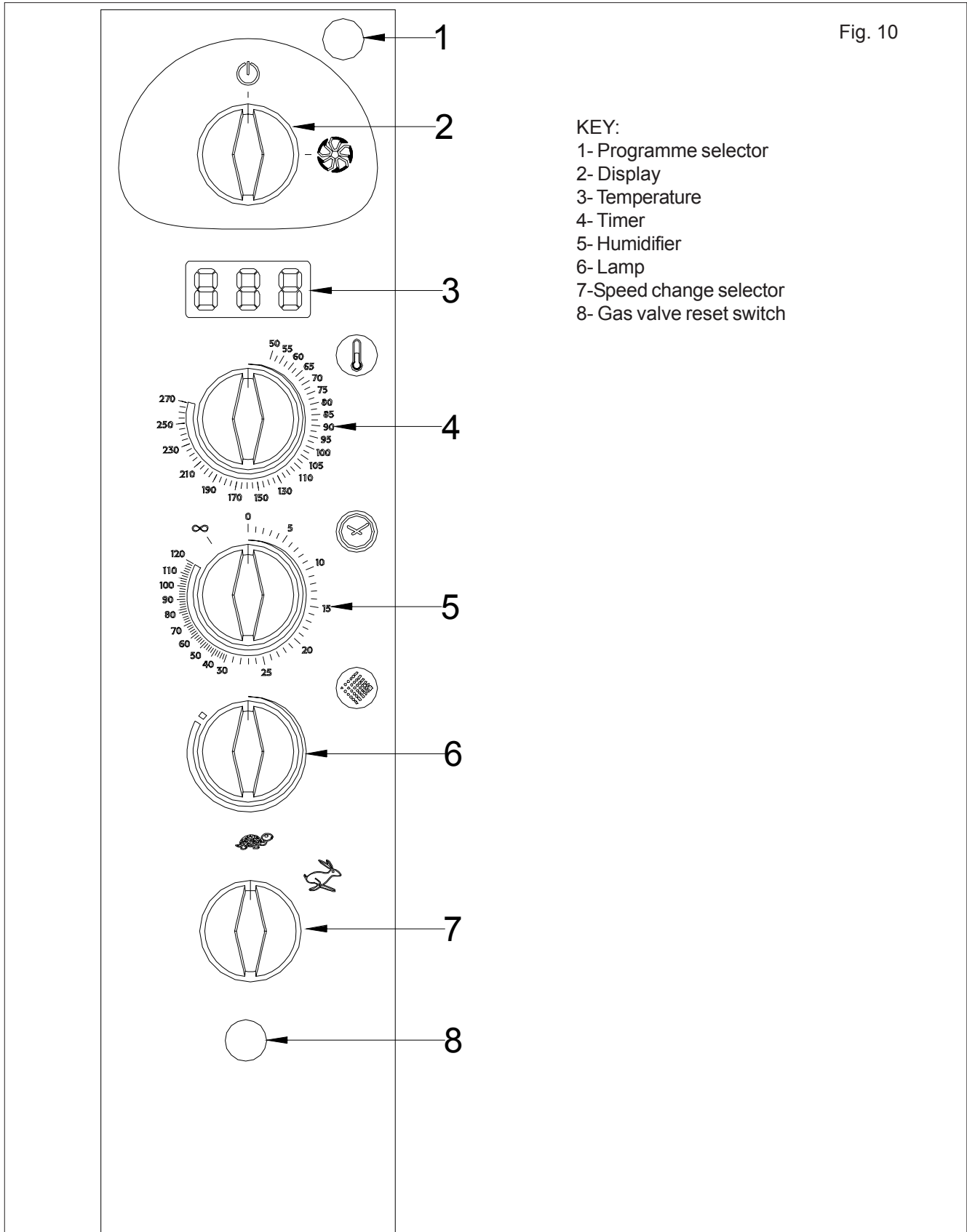

2.1 COMMISSIONING

Before using the appliance for the first time, remove all packing material. Do not use metal pads or other abrasive material.

To start up the appliance, switch on the master switch and open the water and gas stopcock upstream of the appliance.

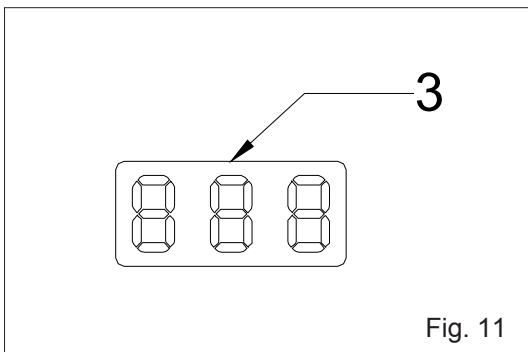

DISPLAY

The oven features a single control display panel (3) which lights when the programme selector is rotated.

The display shows the temperature inside the oven compartment.

2.2 SETTING

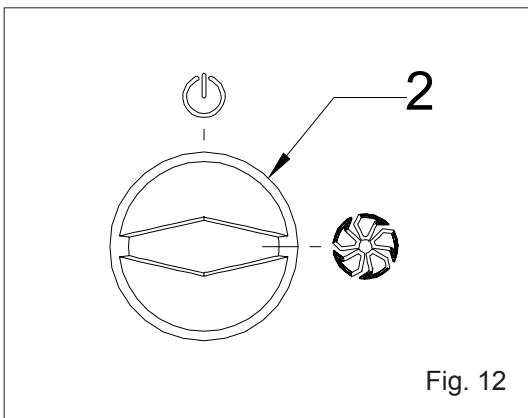

SWITCHING ON

To start the cooking cycle, turn selector (2) to position 1, as shown in Fig.12.

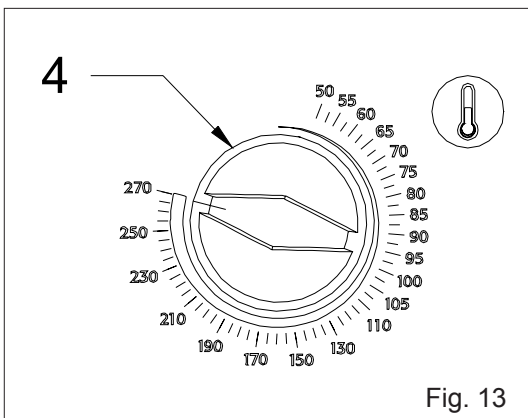

TEMPERATURE

Turn the knob (4) clockwise in order to select the desired cooking temperature (up to a maximum of 270°C).

While the oven is in operation, the display will show the temperature inside the oven.

The temperature setting may be modified at any time during the cooking cycle simply by turning the knob to the desired temperature.

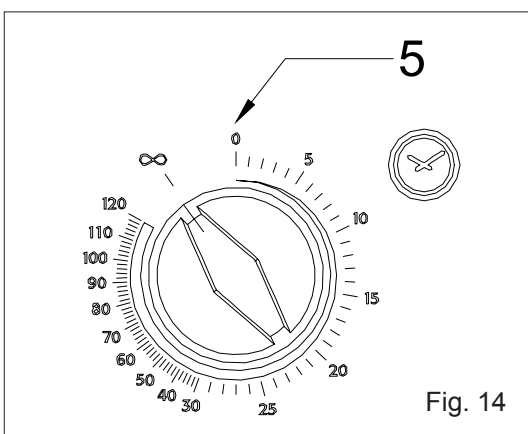

TIME

All cooking cycles can be performed with or without timer control of the duration of the cooking cycle.

Turn the timer knob (5) to the desired cooking time (from 1 to 120 minutes).

When the selected cooking time has elapsed, the oven switches off automatically and the buzzer sounds.

To set the oven to manual cooking (i.e. without timer control), turn the knob (5) to the position shown in the figure opposite.

2.3 SUPPLEMENTARY FUNCTIONS

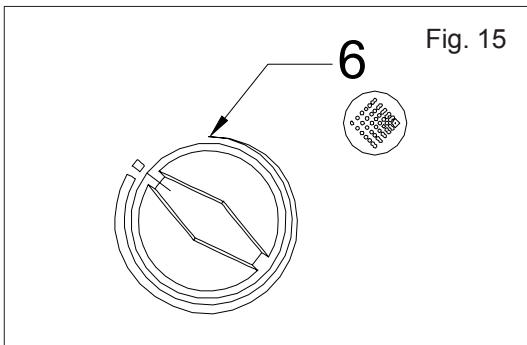

HUMIDIFIER

The humidifier function can be selected for the convection cooking cycle only. If other cooking cycles are selected, the humidifier function is automatically disabled.

The level of humidity inside the oven is increased by turning the humidifier knob (6), which introduces nebulized water into the oven. If the humidifier knob is turned to the position shown in the figure opposite, nebulized water will be introduced continuously.

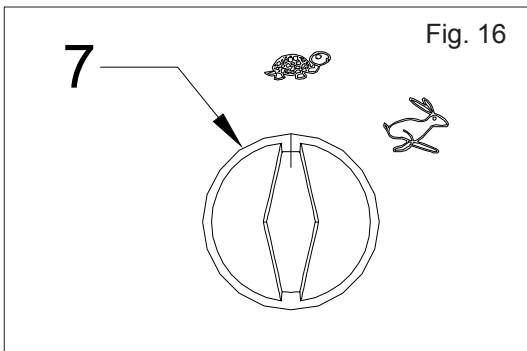

SPEED CHANGING

The speed change enables the oven fan to be run at two different speeds:

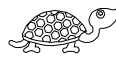

low speed



high speed

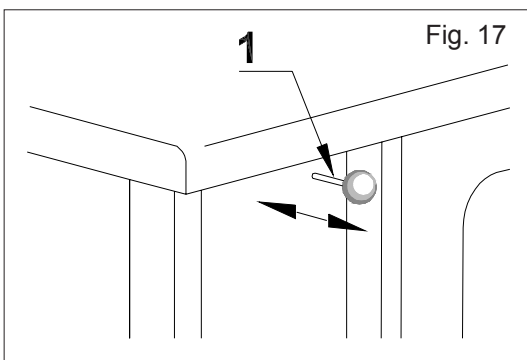

CONDENSATE VALVE CONTROL

The condensate discharge valve expels any steam that might form in the chamber during a cooking cycle.

Pull the knob (1) to open the valve by the amount required to allow the steam to escape. Push the knob in completely to completely close the valve and prevent any steam from escaping.

Even if the valve is completely closed, there is no risk of too much pressure building up inside the chamber because pressure is controlled by the vent.

2.4 SWITCHING OFF

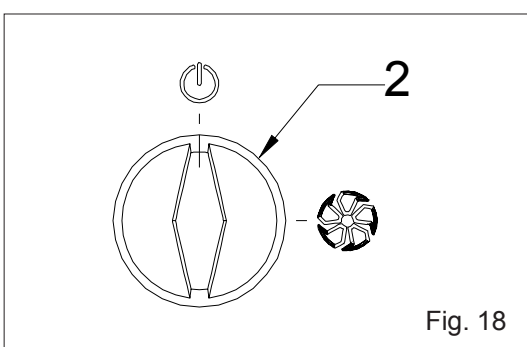

Turn master switch (2) to "0" and return all switches to initial position. Shut off the water and gas stopcock upstream of the appliance. Switch off master switch on wall.

2.5 CLEANING

At the end of a working day, the appliance must be cleaned for reasons of hygiene and also in order to prevent operating faults.

Do not clean the appliance with direct or high-pressure jets of water and do not use steel pads, brushes or scrapers in normal steel. If necessary, stainless steel wool can be used if it is rubbed in the same direction as the grain of the satining.

Wait for the oven chamber temperature to fall below +50°C and slightly lift the shelf supports to remove the shelves. Remove any loose residue by hand and put the filter and all removable parts in the dishwasher. On steel surfaces, use warm soapy water and rinse with plenty of water. Dry with a soft cloth.

3.

MAINTENANCE

CLEANING

The oven is cleaned in three phases.

- Remove the shelf supports, run a 10-15 minute cycle at 130°C with maximum humidity.
- Spray a cleaning product inside the oven and let it take effect.

WARNING: the product used for cleaning the oven must not contain chlorine and must be suitable for the set temperature.

- Run a 10-15 minute cycle again at 130°C at maximum humidity.

At the end of the cleaning phases, the oven can be dried by running it for a short period with the humidification function switched off.

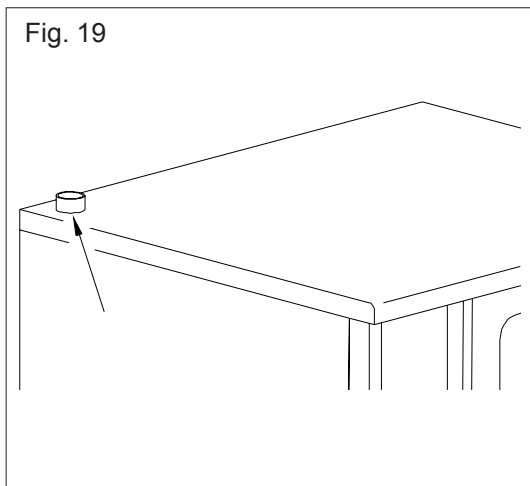

STEAM VENT

The steam vent expels the steam produced inside the oven. Check that it is always clean and completely unobstructed.

3.1 SAFETY AND MONITORING COMPONENTS

SOLENOID VALVE

The solenoid valves are devices for supplying water at set times in set ways.

DOOR MICROSWITCH

The door's microswitch disconnects heating and fan operation when the oven door is opened. When the door is closed, normal operations resume.

Do not use this device in manual mode when the oven door is open.

MOTOR THERMAL OVERLOAD PROTECTION

The fan motor has a built-in thermal overload protection device that stops fan operations if it overheats. Operations resume automatically as soon as the motor temperature has fallen sufficiently to allow operations to resume.

SAFETY THERMOSTAT

If the temperature inside the oven reaches 350°C, the safety thermostat disconnects the gas supply to the burners. This safety device must be reset only by an after-sales technician because further checks are required.

FLAME CONTROL

The flame control uses an electrode to ensure correct burner operation.

If the burners accidentally go out or if they are faulty, the system automatically cuts off the gas supply and the warning light on the control panel comes on (Fig.10 Ref. 8).

Wait at least 10 seconds between one attempt to light the burners and another.

4.

WHAT TO DO IF

If a fault occurs it is **vitaly important** to switch off the appliance at the master switch and to shut off the water and gas stopcocks upstream of the appliance.

THE OVEN DOES NOT START

Check that the master switch is in the ON position.
Check that the gas stopcock upstream of the appliance is open.
Check that the oven door is closed properly.
Check that the settings are correct.
Check that the valve reset button is off.
If the oven still does work after these operations, contact the after-sales service.

THE VALVE CONTROL SWITCH COMES ON

Check that the gas valve upstream of the appliance is open.
Press the switch to reset.
Wait at least 10 seconds between one resetting attempt and the next.
If the oven still does work after these operations, contact the after-sales service.

THE FAN STOPS DURING OPERATION

Switch off the oven and wait for the motor to restart automatically.
Make sure that the cooling vents are not obstructed.
If the problem recurs, contact the after-sales service.

THE OVEN DOES NOT PRODUCE HUMIDITY

Make sure that the stopcock upstream of the appliance is open.
Check the humidifier selector setting.
If the problem persists, contact the after-sales service.

THE INTERIOR LIGHT DOES NOT WORK

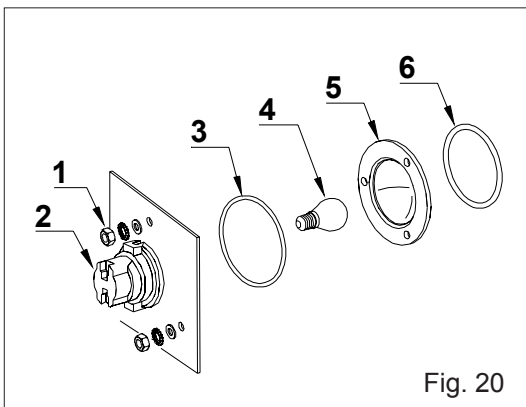

Change the interior lighting bulb inside the oven.
Remove the left-hand side of the oven and remove the parts shown in Fig. 20.

Use heat-resistant bulbs.

- 1- Nuts
- 2- Light holder
- 3- O-Ring
- 4- Bulb
- 5- Hardened cone
- 6- O-Ring

4.1 CHECK MUST BE CARRIED OUT ONLY BY AN AUTHORISED TECHNICIAN

DISCONNECT THE POWER SUPPLY BEFORE CARRYING OUT ANY ADJUSTMENT OR WORK

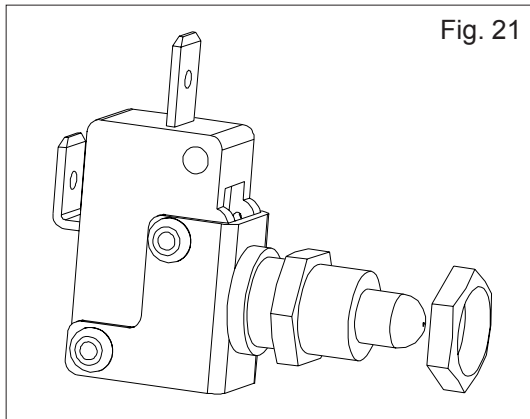

ADJUSTING DOOR MICROSWITCH

To adjust the position of the door microswitch, adjust the nut and counternut.

Check that the microswitch contact is closed only when the door closes.

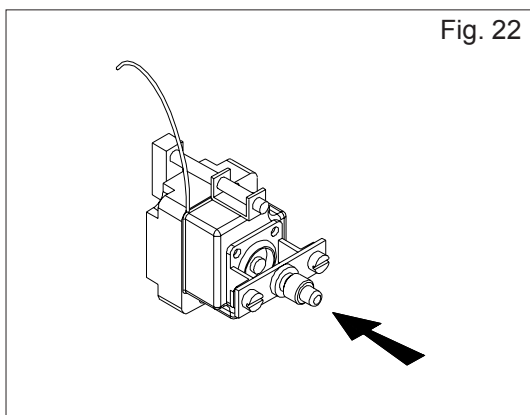

RESETTING SAFETY THERMOSTAT

Open the control panel, press the red button until the contacts are closed. When they are closed, you will hear a mechanical 'click'.

If the safety thermostat is being constantly tripped, the appliance is faulty.

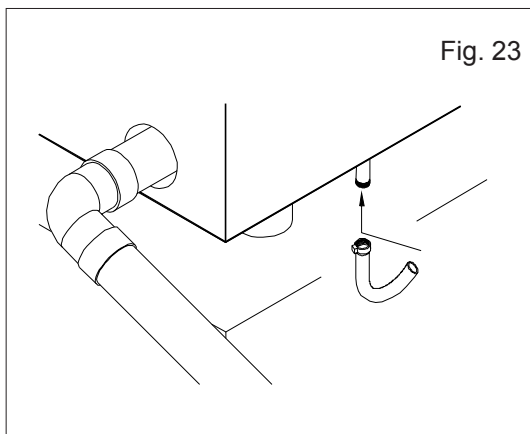

WATER FILTER:

If water does not enter the oven, check the filter on the intake to the solenoid valve. Proceed as follows:

- close the water tap ahead of the oven;
- disconnect the tube from the intake;
- use a pair of pliers to remove the filter from inside the solenoid valve;
- clean the filter and put it back into place;
- reconnect the tube to the intake;
- reset the safety thermostat.

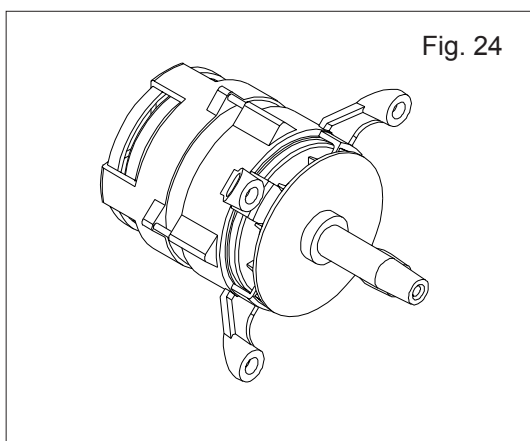

MOTOR OVERLOAD PROTECTION

The motor's overload protection device is reset automatically. If it is tripped, check the vents and the cooling devices and check for smooth rotation.

Disconnect the power supply.

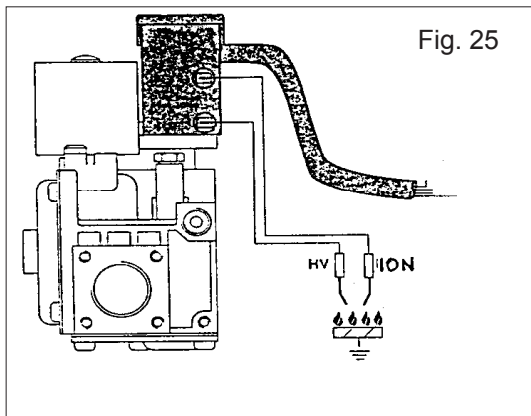

Fig. 25

FLAME CONTROL

WARNING:

THE FLAME CONTROL WILL WORK CORRECTLY ONLY IF THE PHASE AND NEUTRAL WIRES HAVE BEEN POSITIONED CORRECTLY.

Adjust the flame control electrode in such a way that it is immersed in the flame whilst the burners are operating. Otherwise, it will not give enable the gas valve.

Position the spark plug at between 2 to 4 mm from the burner in the area with holes at the start of the gas burner. After shutting off the gas supply, check that the spark plug sparks.

Wait at least 10 seconds between one attempt to use the spark plug and the next.

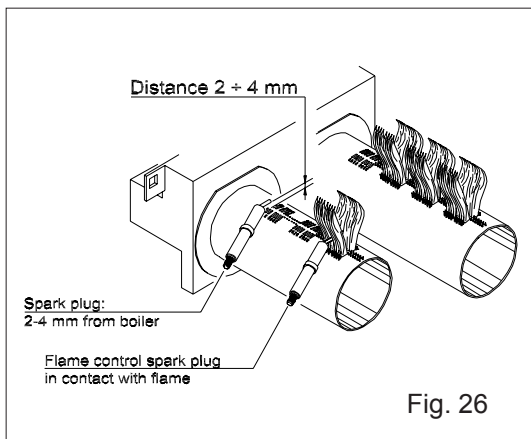

Fig. 26

THE MANUFACTURER ACCEPTS NO RESPONSIBILITY FOR HARM CAUSED BY INCORRECT INTERVENTIONS, TAMPERING WITH THE APPLIANCE, MISUSE, POOR MAINTENANCE, NON-COMPLIANCE WITH CURRENT REGULATIONS AND INEXPERT USE.

THE MANUFACTURER RESERVES THE RIGHT TO WITHOUT NOTICE MODIFY THE FEATURES OF THE APPLIANCES DESCRIBED IN THIS MANUAL.